



JÄGER

EnviroTech

Bioneering Wastewater Aeration with High Efficient Diffusers and Biofilm Technologies: Insights from Jaeger EnviroTech



How **Al-Mousa Trading Co.** Piping Technologies Are Redefining Performance in Mega Infrastructure Projects

FILTRALITE®

Filtralite® Filter Media: Driving Sustainable Water Treatment with Lower Energy and Reduced Carbon Footprint



How **Next Turbo** Blowers Are Redefining Aeration Efficiency in Middle East WWTPS



Optimizing Wastewater Treatment Processes: **BINDER** Group's Intelligent Aeration Control Systems



Enhancing Water & Wastewater Treatment Performance with **ARTAS** Advanced Electromechanical Solutions

Hans-Christian von Consbruch
Managing Director of Jaeger EnviroTech





AquaEnergy Expo
Magazine
Blue | Green | Sustainable | Smart

Digital Magazine Advertising

Aqua Energy Expo magazine includes more than 1000 unique articles and news about global Water and Energy fields



To download the Latest comma
Visit our Digital Magazine

www.mg.aquaenergyexpo.com

Innovative Solutions to Achieve Sustainability in Water and Energy

From The Editor

Welcome to this issue, where we explore the cutting-edge innovations transforming water and wastewater management. Today, the global water sector faces unprecedented pressures from climate change, rapid urbanization, and aging infrastructure. With global water demand projected to increase by more than 50% by 2050, the industry must shift toward highly efficient, sustainable, and decentralized technologies.

In this issue, we highlight how **Jaeger EnviroTech** continues to pioneer sustainable biofilm solutions, utilizing high-quality elastomer membranes to maximize durability in municipal and industrial applications. We also examine **Next Turbo Technologies**, whose constant-speed centrifugal blowers utilize dual modulating vane control to offer a more stable and efficient alternative to traditional variable frequency drives. Aeration remains the most energy-intensive process in wastewater treatment facilities. **BINDER Group** is utilizing artificial intelligence within its VACOMASS® system to perform dynamic aeration control, successfully reducing energy consumption by up to 50%.

On the mechanical side, **ARTAS** provides the essential reliability needed through high-performance screens and scrapers. In biological treatment, MBBR technology provides a space-saving, low-sludge solution for modern facilities. Filtration and desalination are also seeing radical improvements.

Filtralite® expanded clay media is replacing sand to slash energy costs by up to 75%. In Saudi Arabia, **Al-Mousa Trading Co.** a strategic partner of GRUNDFOS is powering mega-projects like King Abdulaziz International Airport with AQUATERRA piping and GLS tanks. In Egypt, **Naqaa Water Treatment** is delivering integrated systems utilizing LOREX pumps and Jacobi carbon.

Veolia's Barrel™ technology is streamlining reverse osmosis with a 25% smaller footprint. Chemical treatment is being revolutionized by SafeGuard H₂O, which generates ferrate on-site to remove contaminants without the hazards of transporting bulk chemicals.

Ultimately, the issue balances high-tech breakthroughs with the humanitarian need for low-cost, gravity-based systems. By prioritizing both industrial efficiency and accessible solutions for the 2.2 billion people lacking safe water, the engineers and companies featured are securing a sustainable resource for future generations.



Mohamed Khalifa

Founder and CEO

COMPANY:

AQUA ENERGY EXPO LLC

ADDRESS:

(ST. PETERSBURG, FLORIDA USA 33702)
(L23000439864), EIN (61-2116509)



Email Address:

Info@aquaenergyexpo.com



AquaEnergy Expo
Magazine
 Blue | Green | Sustainable | Smart

AQUA ENERGY EXPO TEAM



Magazine Team



Mohamed Khalifa
 Founder and CEO

Team leader
Heba Sayed

Design

- Hadeer Omar
- Omnia Gamal
- Nesma Saeed
- Walaa Mohamed

Content Writers

Water Section

- Hadeer Omar
- Aya Mohsen

Energy Section

- Omnia Gamal

Virtual Expo Team

- Heba Taha

Webinars Team

- Hadeer Omar
- Haidy Walid
- Khlood Khaled
- Heba Taha

Social Media Team

- Heba Taha

Knowledge Hub Team

- Esraa Hany

Marketing Team

- Heba Sayed : Heba@aquaenergyexpo.com
- Esraa Hany : Esraa@aquaenergyexpo.com
- Khlood Khaled : Khlood@aquaenergyexpo.com
- Haidy Walid : Haidy@aquaenergyexpo.com
- Hagar Wali : Hager@aquaenergyexpo.com

Issue Contents

Features

Page 09: Bioneering Wastewater Aeration with High Efficient Diffusers and Biofilm Technologies: Insights from Jaeger EnviroTech



Page 14: How Next Turbo Blowers Are Redefining Aeration Efficiency in Middle East WWTPs

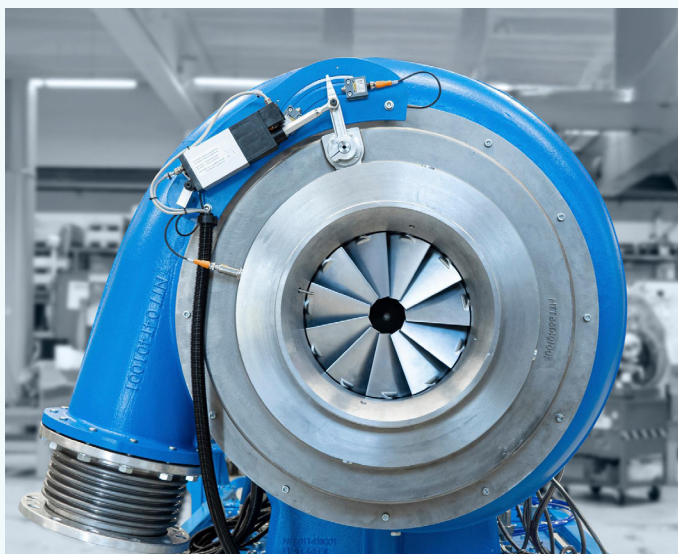

Page 17: Optimizing Wastewater Treatment Processes: BINDER Group's Intelligent Aeration Control Systems



Features

Page 20: Enhancing Water & Wastewater Treatment Performance with ARTAS Advanced Electromechanical Solutions



Page 25: Filtralite® Filter Media: Driving Sustainable Water Treatment with Lower Energy and Reduced Carbon Footprint



Page 28: How Al-Mousa Trading Co. Piping Technologies Are Redefining Performance in Mega Infrastructure Projects

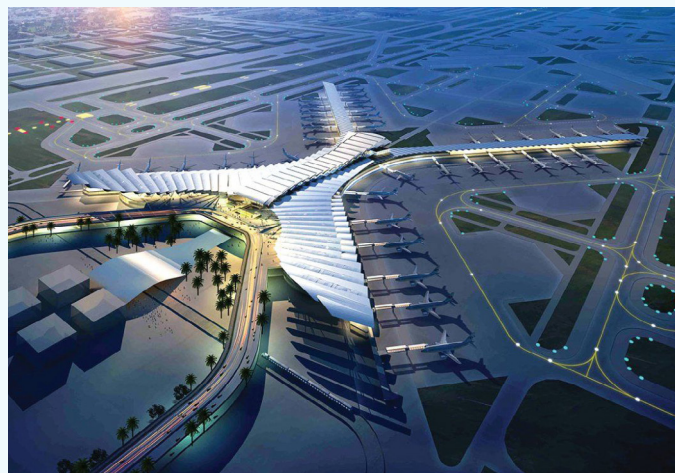

Issue Contents

Webinars

Page 36: Webinars



Water News Brief

Page 37: Water Monthly News Brief



Water Events

Page 40: Global Water Events



Water Treatment

Page 44: Naqaa Water Treatment Technology: Company Profile



Desalination

Page 51: Veolia: Leading the Way in Desalination Solutions for a Secure Future



Issue Contents

Water Treatment

Page 58: Overcoming Infrastructure Barriers: Low-Cost Alternatives to Conventional Water Treatment



Wastewater Treatment

Page 61: MBBR Technology: The Sustainable Solution for Modern Industrial Wastewater Treatment



Page 66: Phosphate Management Revolution: Innovative Solutions for Protecting Water Resources and Achieving Environmental Sustainability



Energy News Brief

Page 71: Energy Monthly News Brief



Energy News Brief

Page 74: Global Energy Events





AquaEnergy Expo

Magazine

Blue | Green | Sustainable | Smart

Now for Free & for a Limited Time

Show your products in the global virtual expo for water and energy products

Joining the virtual expo will help you to increase your customers network, grow your sales, publish your brand, find new distributors and agents and open new markets

*The virtual expo of water and energy products contains more than **16400** products and more than **1220** companies from more than **195** countries around the world*



To add your company for free contact us

WhatsApp (+966 505308851)

www.aquaenergyexpo.com



Bioneering Wastewater Aeration with High Efficient Diffusers and Biofilm Technologies: Insights from Jaeger EnviroTech

As global wastewater challenges intensify and sustainability becomes a central priority, Jaeger EnviroTech Company stands out as a pioneer in aeration and biofilm technologies. Building on an engineering legacy that dates back to the 1970s, the company has continuously advanced diffusers and fixed bed biofilm solutions to improve the efficiency of aeration in wastewater treatment while reducing energy consumption and operational costs. In this exclusive interview, Hans-Christian von Consbruch, Managing Director of Jaeger EnviroTech, shares insights into the company's innovation journey, its integrated approach to aeration and IFAS technologies, and how its sustainable, high-performance solutions are shaping the future of wastewater treatment worldwide.



Hans-Christian von Consbruch
Managing Director at Jaeger EnviroTech

Can you give us a brief overview of Jaeger EnviroTech and its journey since inception?

At Jaeger EnviroTech, we see ourselves as pioneers in aeration and biofilm technology. Our story goes back to the early 1970s, when Arnold Jäger created the world’s first intermittently operable tube diffuser, essentially laying the foundation for today’s membrane diffuser industry. Since then, we’ve built on that legacy with a strong focus on engineering excellence and sustainability. Today, we deliver high efficiency environmental solutions to customers around the world, always backed by decades of hands-on expertise.

How many years has the company been operating, and how many employees does it currently have?

We formally founded Jaeger EnviroTech in 2007 as “Jäger Umwelt-Technik”. Since then, our team has grown to around 40 dedicated colleagues, engineers, environmental technicians, biologists, and highly skilled production specialists. Every single one of them contributes to the performance, quality, and innovation our customers rely on. B.t.w., last year we changed our name officially from “Jäger Umwelt-Technik” to “Jaeger EnviroTech”.

Does Jaeger EnviroTech manufacture products exclusively in Germany, or are there production facilities elsewhere?

Our core technologies — aeration systems and IFAS systems — are manufactured right here in Hannover, Germany. We’re part of the long-established JÄGER Group, and we benefit from their manufacturing strength and experience.

For regional markets, our sister companies JRP (China) and JET (India) produce diffusers locally, ensuring competitive lead times and high availability.

“ For regional markets, our sister companies JRP (China) and JET (India) produce diffusers locally, ensuring competitive lead times and high availability. ”

How many countries does Jaeger EnviroTech have representatives or distributors in? Are there plans for new distribution lines?

We’re active across the world with installations on multiple continents. Over the years, we’ve built a strong network of international partners and representatives, and we continue to expand through strategic collaborations. Wherever wastewater is treated, our technologies can make a difference, and usually already do.

What are the company’s core products, and what makes them stand out in the market?

Our portfolio focuses on two main pillars:

- JetFlex® Diffusers (tube, disc and strip diffusers)



- CLEARTEC® Fixed Bed Biofilm Systems (BioTextil, BioCurlz)

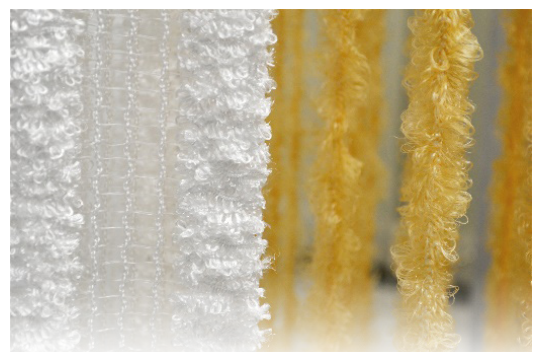

Our diffuser technologies stand out because they deliver excellent oxygen transfer, long membrane lifetimes, modularity, and a strong sustainability profile.

CLEARTEC® is our textile fixed bed biofilm technology, a robust, low energy, self regulating system that can increase the biological treatment capacity by up to 50% while keeping energy consumption low compared to many MBBR solutions.

Products & Innovation

Can you explain the materials used in your diffusers & how they contribute to performance and durability?

We use high quality perforated elastomer membranes and recyclable plastics. Over decades, we've developed special EPDM compounds that maximize durability in municipal and industrial applications.

For especially challenging conditions and wastewater characteristics, we rely on silicone membranes (high heat and UV resistance) or PU membranes (excellent chemical and tear resistance). Our latest diffuser designs use recycled materials, require no adhesives, reduce the CO2 footprint, and are fully recyclable, benefitting both our customers and the environment.

How do you decide which type of diffuser is suitable for a particular project or application?

No two wastewater treatment plants are the same. We consider basin geometry, airflow, oxygen demand, wastewater composition, and the operating mode (continuous or intermittent). Based on this, our engineering team defines the optimal solution to ensure reliability, energy savings, and long-term performance.

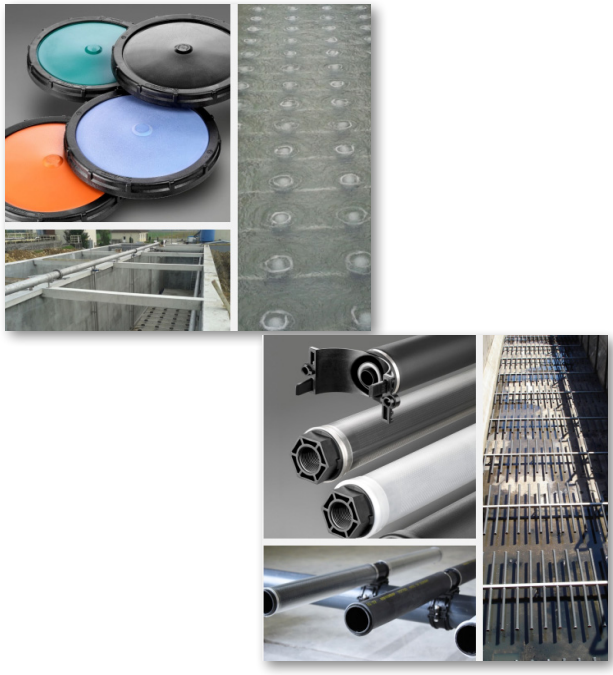

What are the key advantages of Jaeger EnviroTech diffusers over competitors' products?

Our customers value us because we offer:

- Proven products with
 - High oxygen transfer efficiency
 - Long membrane lifetimes
- Tailor-made engineering for each application
- In-house production with complete control of every manufacturing step
- Strong sustainability credentials
- Decades of expertise and thousands of successfully running systems

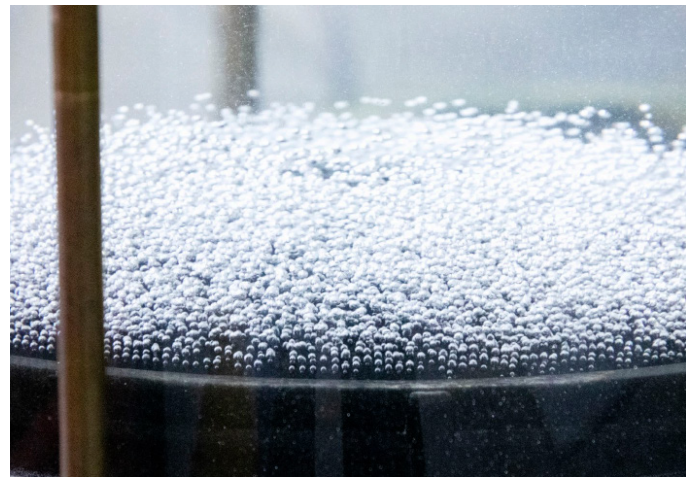

Are there self-cleaning features or innovations in your diffusers that reduce maintenance needs?

Thanks to our membrane design and material compositions, fouling and scaling are significantly reduced. Our elastomer membranes maintain their elasticity and pore integrity, enabling excellent self-cleaning during operation — minimizing maintenance needs.

How can a customer tell when a diffuser requires maintenance, and how often is it typically needed?

A diffuser typically requires attention when oxygen transfer drops, backpressure rises, or airflow becomes uneven. However, thanks to our durable materials and design, maintenance intervals are usually long and predictable.

Does Jaeger EnviroTech offer other advanced technologies, such as biofilm systems or CLEARTEC® modules?

Beyond diffusers, we also offer our ShearCon® Process, an advanced fixed bed biofilm solution based on our CLEARTEC® technology.

ShearCon® increases nutrient removal rates in the suspended biomass and improves sludge settling at the same time.

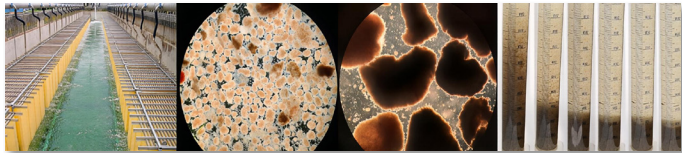

How do these additional technologies complement your aeration systems and enhance performance?

When we combine JetFlex® aeration with CLEARTEC® modules, we increase biomass retention, boost treatment capacity, stabilize biological processes, and reduce energy demand. This combination is especially beneficial for IFAS and hybrid treatment systems.

What upcoming innovations or product developments should the market expect from Jaeger EnviroTech?

We are continuously advancing ShearCon® and our membrane technologies. Our R&D efforts focus on sustainability, improved materials, and smarter system integration — ensuring our customers benefit from innovations that truly matter.

Projects & Impact

How many units/projects has Jaeger EnviroTech completed globally, and in how many countries?

Our technologies are used worldwide — in municipal, industrial, and specialized wastewater applications. A full list of our reference projects is available for download on our website, and it demonstrates just how broad and international our experience is.

What is the largest project you've executed, and in which country was it implemented?

To the best of my knowledge, our largest diffuser installation is located in Bahrain (400,000 m³/day), while our largest CLEARTEC® project is in London UK (roughly 200,000 m³/day). That said, we have delivered major aeration and biofilm solutions across many countries and for some of the world's largest wastewater treatment facilities.

What is the largest project you've executed, and in which country was it implemented?

To the best of my knowledge, our largest diffuser installation is located in Bahrain (400,000 m³/day), while our largest CLEARTEC® project is in London UK (roughly 200,000 m³/day). That said, we have delivered major aeration and biofilm solutions across many countries and for some of the world's largest wastewater treatment facilities.

Could you share some of the most notable case studies where Jaeger EnviroTech products significantly improved energy efficiency or operational performance?

Our website features numerous case studies showing how JetFlex® & CLEARTEC® systems significantly improve oxygen transfer, reduce energy consumption, and increase treatment capacity. These results are not theoretical — they are proven in real plants.

What are the main challenges your products solve in wastewater treatment or other applications?

We help our customers address:

- Insufficient dissolved oxygen / high aeration energy consumption
- Weak removal rates, poor sludge settling, or limited biomass
- Maintenance challenges through low-maintenance diffuser designs and liftable aeration grids



Market Position & Strategy

Why should a customer choose Jaeger EnviroTech over another vendor?

Customers trust Jaeger EnviroTech because we offer:

- Close customer support and hands-on service
- Deep consulting expertise in aeration and IFAS systems
- Tailor-made, low OPEX solutions
- Reliable products
- Unique integration of aeration and biofilm systems
- A strong sustainability focus

What is Jaeger EnviroTech's current market share at a global level?

We don't publish market share numbers, but we know that we are recognized internationally for our long-standing expertise in fine bubble aeration and biofilm technology. Our presence in key global markets speaks for itself.

How does Jaeger EnviroTech ensure quality, reliability, & customer satisfaction across its international projects?

Quality is a core principle for us.

We ensure it through:

- A zero defect philosophy
- Strict German engineering and manufacturing standards
- Continuous improvement and R&D
- Strong technical support
- Sustainability-focused product development

Future Vision & Recognition

Where does Jaeger EnviroTech see the wastewater aeration technology market heading, and how are you preparing for these trends?

We see the industry moving toward:

- Higher energy efficiency
- Wider use of hybrid and IFAS biofilm systems
- More sustainable, low carbon treatment processes
- Digitalization and AI for process optimization

We are preparing for this future with innovations like the new Smart Strip Diffuser or the innovative ShearCon® process.

Has Jaeger EnviroTech received any industry awards or certifications that highlight its credibility and innovation?

We hold DIN ISO certifications 9001, 14001, and 50001 — all available on our website. We also participate regularly in leading conferences and trade fairs such as IFAT (Germany, China, India), WEFTEC (USA), and Asia Water, reflecting our commitment to innovation and international cooperation.





How Next Turbo Blowers Are Redefining Aeration Efficiency in Middle East WWTPs

Selecting the appropriate blower technology is a critical decision in wastewater treatment plants, as it directly affects energy efficiency, operational flexibility, and lifecycle cost. Different blower technologies exist, each with its own operating principle and performance characteristics. Wastewater treatment plants in the Middle East often operate under challenging environmental conditions, including high ambient temperatures, fluctuating electricity quality, and varying process loads. Under such conditions, equipment reliability, electrical stability, and energy efficiency become critical design priorities.

The constant-speed centrifugal blower concept used by Next Turbo Technologies provides several advantages in these environments, including stable operation, reduced sensitivity to electrical harmonics, and improved efficiency across varying operating conditions.

Overview of Common Blower Types

Air blowers used in wastewater treatment plants can generally be categorized into two main groups: volumetric machines and centrifugal machines.

Volumetric machines include technologies such as positive displacement (PD) blowers, commonly known as Roots blowers, which operate by trapping air in a defined volume and transporting it from the inlet to the discharge side. This design relies on moving a fixed volume of air with each rotation.

On the other hand, centrifugal machines work by increasing the speed of air and converting this speed into pressure. These machines include several configurations such as single-stage centrifugal blowers, multistage blowers, and screw blowers.

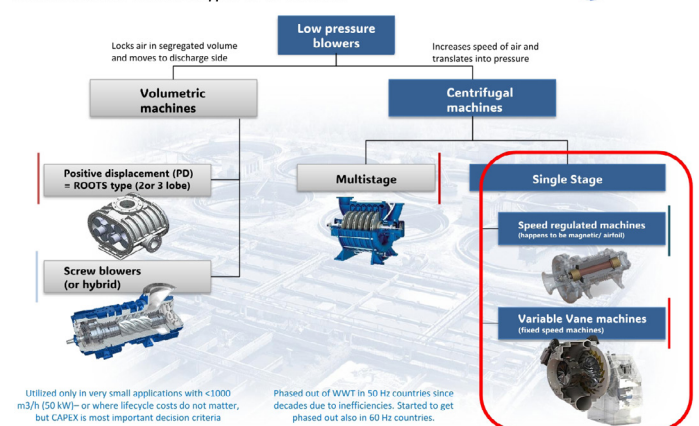

Efficiency Advantages of Single-Stage Centrifugal Blowers

Among centrifugal technologies, single-stage centrifugal blowers have become an attractive solution for modern wastewater treatment plants due to their efficiency and operational flexibility.

The efficiency of a blower system is strongly influenced by the way airflow is regulated to match the process demand. While many systems rely on speed control using a variable frequency drive (VFD), this approach is not always the most efficient solution for centrifugal machines.

Instead, systems using dual modulating vane control can achieve higher efficiency across the operating range.

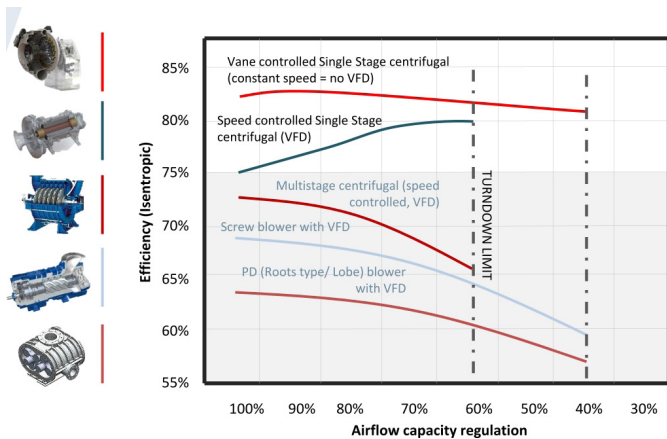

According to efficiency comparisons:

- » Dual modulating vane control systems typically achieve 80–84% efficiency.
- » Speed control systems using VFD usually operate within 70–84% efficiency.

This represents an average efficiency advantage of approximately 8–10 percentage points when using modulating vane control instead of simple speed control.

In addition, when comparing centrifugal blowers with Roots (PD) blowers, centrifugal technologies demonstrate superior efficiency across a wider operating range, making them better suited for modern wastewater treatment processes where airflow demand fluctuates significantly. One of the companies that has specialized in advancing single-stage centrifugal blower technology is Next Turbo Technologies.

“Next Turbo blowers are designed based on a constant-speed concept combined with advanced dual modulating vane control. This design philosophy allows the blower to achieve high efficiency while avoiding many of the limitations associated with variable-speed control.”

— Florian Adam,
Sales Director and Member of the Board at Next Turbo Technologies

How to Design a Centrifugal Air Blower That Can Regulate Airflow

A key challenge in blower design is the ability to regulate airflow efficiently while maintaining stable pressure.

Speed Control Using VFD

One common method is regulating airflow by changing the rotational speed of the blower using a variable frequency drive (VFD).

With this approach:

- » Airflow varies proportionally with the rotational speed.
- » Pressure varies proportionally with the square of the speed.

However, this solution requires the blower to be designed for a higher pressure than normally needed in order to maintain control capability. As a result, the blower often operates below optimal efficiency. In addition, this method usually allows airflow regulation only within a range of 75% to 100% of capacity.

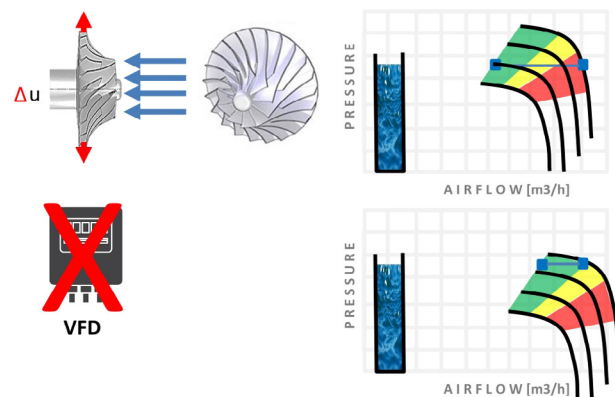

When operating close to the lower flow range, the blower may also approach the surge limit, which can lead to unstable operation, vibration, and increased noise levels.

Continuous operation near this condition may negatively affect reliability and mechanical components over time.

Modulating Vane Control

An alternative approach is modulating vane control, where airflow is regulated through variable diffuser vanes and inlet guide vanes rather than by changing the speed of the blower.

In this design:

- The blower operates at a constant speed.
- No VFD is required.
- No harmonic distortion (THD) is introduced to the electrical network.
- Airflow is regulated without affecting the pressure drop in the system.

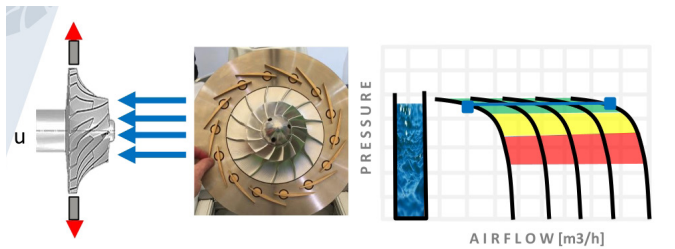

This design principle is implemented in Next Turbo single-stage centrifugal blowers, where airflow is regulated using advanced vane control instead of relying solely on speed variation.

Dual Modulating Vane Control

Constant-speed blower design is further improved by implementing dual modulating vane control, which combines:

- Variable diffuser vanes
- Inlet guide vanes

This configuration allows the blower to optimize performance when external conditions change, such as:

- Fluctuations in suction air temperature
- Changes in barometric pressure
- Variations in system pressure

This approach improves operational stability and efficiency across the full regulation range.

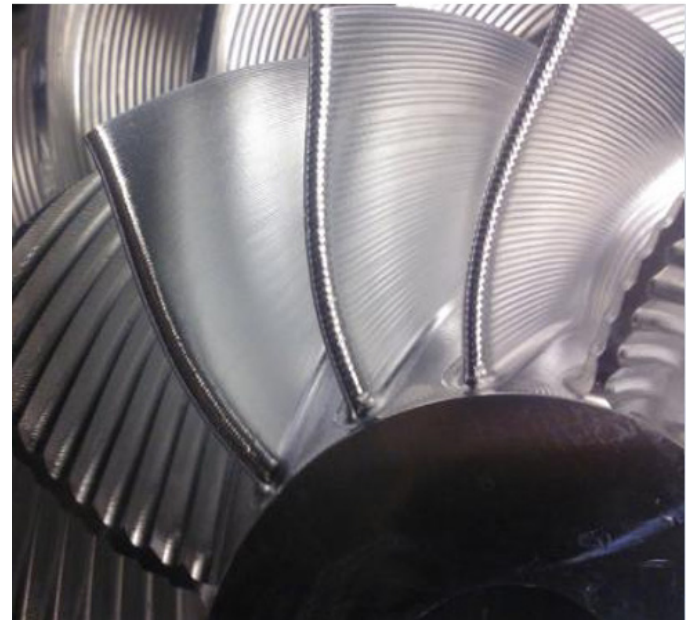

Conclusion

Selecting the right blower technology plays a crucial role in determining the energy efficiency, operational stability, and long-term cost of wastewater treatment plants.

While traditional blower systems often rely on variable-speed control using VFDs, this approach may introduce operational limitations such as surge risk and electrical harmonic distortion. The constant-speed centrifugal blower design with dual modulating vane control offers a more stable and efficient alternative. By combining advanced aerodynamic design with intelligent airflow regulation, Next Turbo Technologies provides a blower solution that delivers high efficiency, wide operational flexibility, and reliable performance — making it particularly well suited for modern wastewater treatment plants in the Middle East.





Optimizing Wastewater Treatment Processes: BINDER Group's Intelligent Aeration Control Systems

BINDER Group develops technologies for modern wastewater treatment plants with a focus on process optimization and energy saving. The company provides systems and equipment designed to improve aeration control, increase process reliability, and reduce energy consumption in wastewater treatment processes.

The Aeration System: Components and Equipment

The aeration system in biological wastewater treatment consists of several components working together in one integrated system. These components include blowers, air flow meters, control valves, sensors, process control systems, diffusers, pumps, and mixers.

All components influence each other within the system, and some of them change their properties over the years.



VACOMASS®: Aeration Control System

One of the main technologies developed by BINDER Group is the VACOMASS® aeration control system.

VACOMASS® measures, controls, and distributes air to the aeration tanks in a precise and load-dependent way. This allows the system to provide high cleaning performance and process safety while reducing energy consumption.

The system combines innovative technologies and high product quality in order to achieve sustainable investment and the lowest possible life cycle costs.



Precise Air Flow Meter

A key component of the VACOMASS® system is the precise air flow meter.

Airflow meters are typically installed in the main header pipe, subheaders, and dropper pipes for each control zone. These devices use thermal dispersion technology, which is not affected by pressure or temperature changes.

They provide very precise measurements due to customized calibration and have very low pressure drop. A reference sensor measures air temperature, and the signal remains stable over a long period of time with almost no maintenance required.

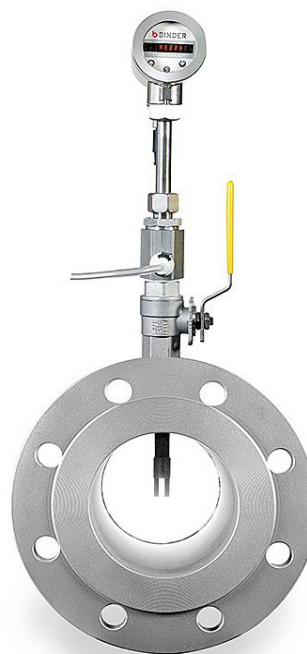

VACOMASS® Jet Control Valve

BINDER developed the VACOMASS® jet control valve, which is an aerodynamically optimized control valve with a linear operational characteristic across a wide operating range.

The valve has a very low pressure loss in the control mode of 2–5 mbar only. Conventional control valves often operate with a 40–70 mbar pressure drop, which increases energy consumption. Due to this low pressure drop, the VACOMASS® jet control valve can achieve direct energy savings of up to 15%.

The valve also features robust construction, an integrated flow conditioner, a short installation length, and gas-tight shut-off.

VACOMASS® Elliptic Diaphragm Control Valve

This aerodynamically optimized diaphragm control valve provides an exceptionally high air flow capacity. The typical pressure drop in control mode is 10–15 mbar, and the valve closes gas-tight.

When the valve opening increases from 70% to 100%, the air flow rate can triple at the same pressure drop, which is ideal for diffuser maintenance and flexible operation.

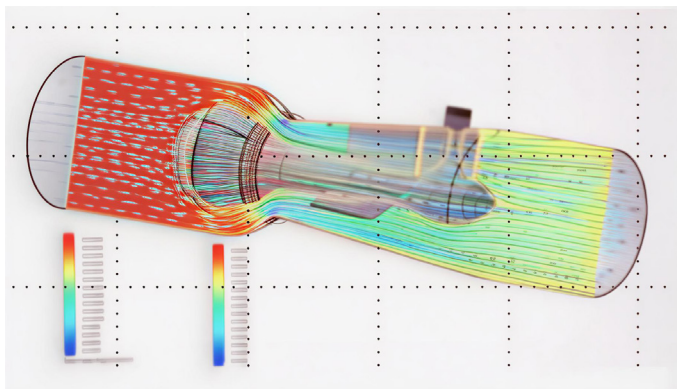
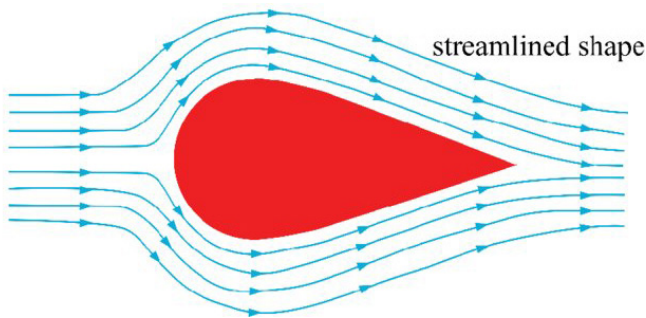

VACOMASS® Flexcontrol: Real-Time Control with AI

This modular PLC-based system works with the plant SCADA system and can be used for new installations as well as renovation or expansion projects. Flexcontrol performs dynamic aeration control in real time with artificial intelligence. The goal is precise and flexible aeration control for demand-driven air supply while controlling blowers, pumps, and other equipment in the aeration system. The system uses actual process information and checks the quality of sensor signals. If a signal fails a plausibility check, the system informs the operator and automatically uses substitute values until the sensor signal becomes valid again.

Energy Savings Achieved by the VACOMASS® System

Reduction of total nitrogen in the effluent can be achieved through precise aeration control, ammonia-based DO control, and improved denitrification.

Energy savings can also be achieved through several factors:

- Pressure drop of the valve: 5–15% energy savings
- Dynamic header pressure: 8–10% energy savings
- Precise aeration control: 10–20% energy savings
- Ammonia-based DO control: 8–15% energy savings
- Diffuser maintenance: 5–15% energy savings



Conclusion

BINDER Group offers advanced control systems for wastewater treatment, focusing on process optimization and energy savings. The VACOMASS® control system includes components like precise air flow meters and control valves that enhance aeration control. This system achieves high performance efficiency while reducing energy consumption by up to 50%. Additionally, the Flexcontrol smart system utilizes artificial intelligence for dynamic aeration control, improving nitrogen removal and enhancing the quality of treated water.

Enhancing Water & Wastewater Treatment Performance with ARTAS Advanced Electromechanical Solutions

Wastewater treatment plants require reliable and efficient equipment to ensure proper operation & environmental protection. Mechanical equipment is crucial for removing solids, handling sludge, and regulating water levels. ARTAS offers durable and efficient systems designed for wastewater treatment facilities, used in both domestic and industrial settings, as well as in irrigation projects and power plants.

ARTAS Engineering and Manufacturing

“With over 43 years of engineering and manufacturing expertise, proven design and quality control, ARTAS Umwelt Technologien GmbH processes guarantee full customer support, ARTAS is your enduring partner.”

ARTAS offers equipment designed with durability and operational reliability in mind. The company also places great emphasis on quality assurance and providing professional service. Artas products are used in 500 projects in 14 countries around the world.

Warranty for 2 years against manufacturing defects. Manufacturing according to ISO 9001, ISO 14001, ISO 45001.

Complete Solutions for Wastewater Treatment

- **Perforated Screens:** Effectiveness in Retaining Small Solids

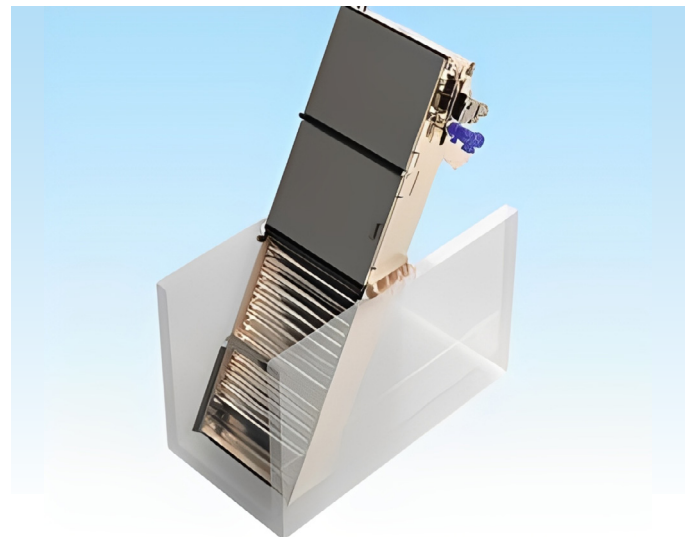

Perforated screens are designed to retain very small diameter solids in wastewater with high efficiency. This fine-screen model reduces maintenance requirements in treatment plants by lowering the risk of clogging and improving operational reliability. The system operates through perforated belts mounted on a chain mechanism that capture solid waste and transport it upward, where it is removed by a brush

system while the belt surface is cleaned with pressurized water to ensure continuous operation.

ARTAS Umwelt Technologien GmbH provides advanced screening systems used in the preliminary treatment stage, including multi-rake bar screens, mechanical arc screens, rotary drum screens, internal flow drum screens, and rope-driven screens. These systems remove coarse and fine solids before wastewater enters subsequent treatment units, protecting pumps, pipelines, and mechanical equipment while ensuring reliable plant performance.

• Mixers

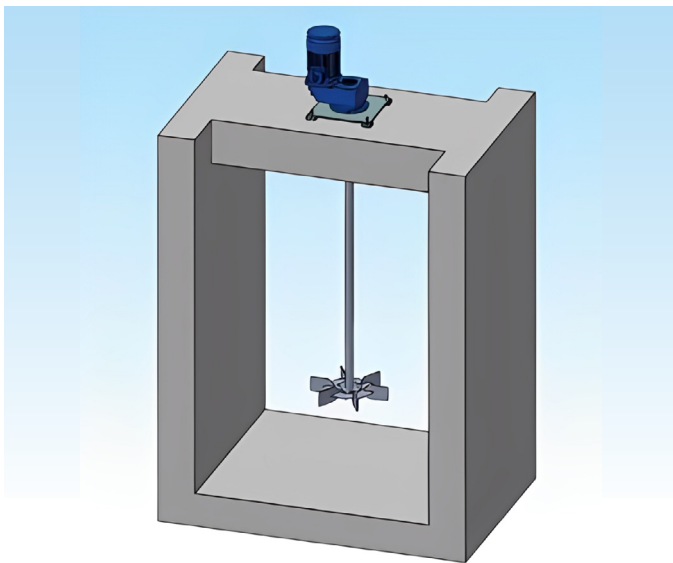

Efficient mixing is essential in many treatment processes such as coagulation and chemical dosing.

Key Advantages

- » High mixing efficiency ensuring uniform distribution of chemicals and liquids.
- » Designed to operate with minimum energy consumption.
- » SCADA monitoring capability.
- » Heavy-duty and reliable design is suitable.

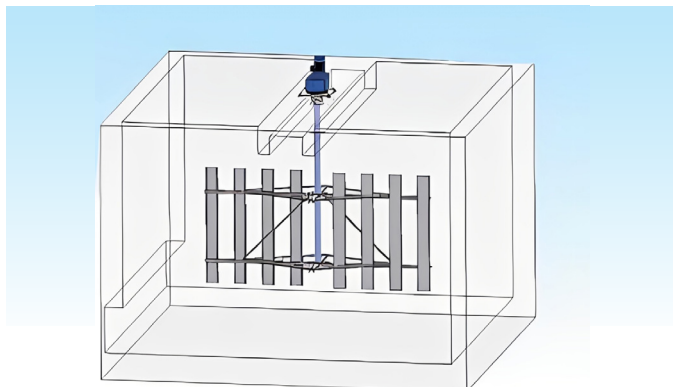

• Penstocks & Weirs

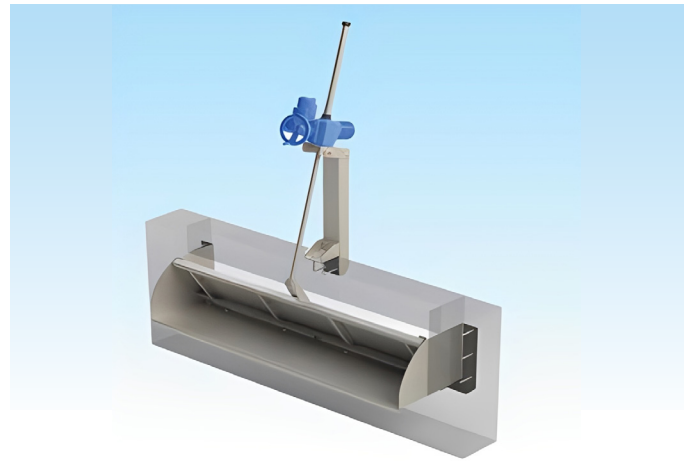

Penstocks and adjustable weirs provide accurate flow regulation and water level control across different treatment stages. Effective sealing is achieved using P- and/or K-type double-lip rubber gaskets. The equipment can be manufactured from stainless steel, galvanized steel, epoxy-coated steel, or aluminum to ensure durability in demanding environments.

Key Advantages

- » Precise water level and flow control.
- » Available with electric or pneumatic actuators for automated operation.
- » SCADA integration for monitoring and remote control.
- » Durable sealing systems ensuring minimal leakage and reliable operation.
- » Simple maintenance.

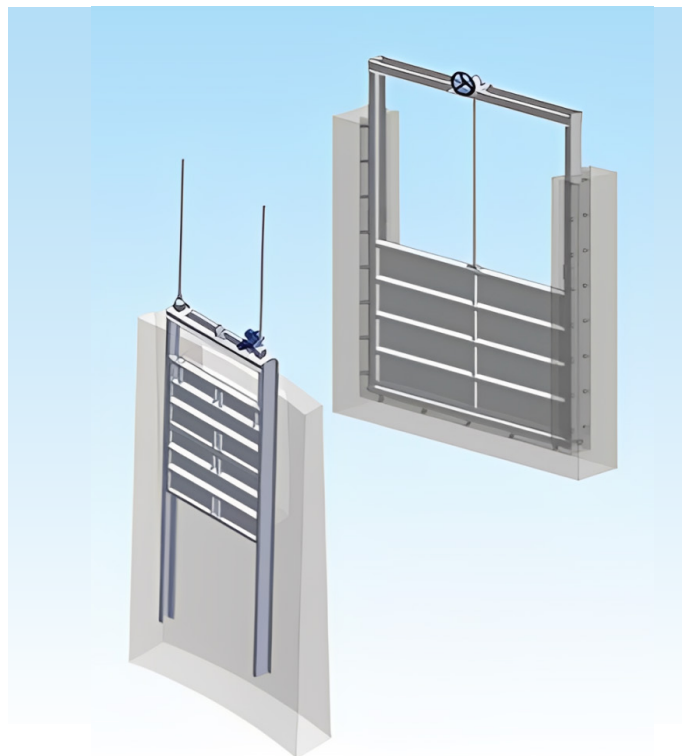

• Clarifier Rotating Bridge Scraper

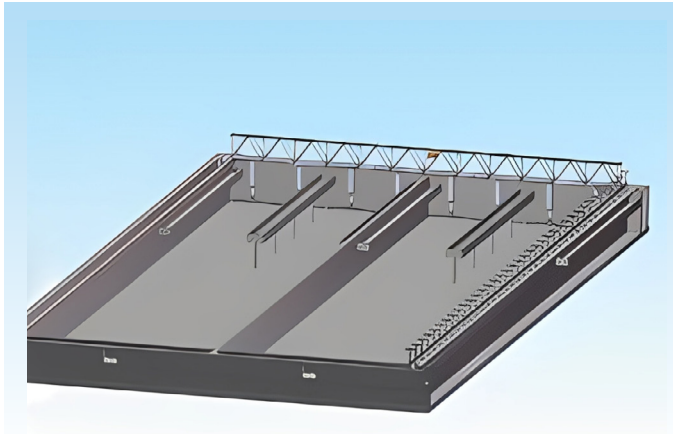

Sludge collection is an important stage in sedimentation tanks and the operation of linear scrapers used in rectangular settling tanks.

Sludge scrapers, used to collect bottom sludge and froth in rectangular settling tanks, move the sludge out of the basin in linear motion.

The operation of the equipment is based on a moving bridge mechanism. Before the bridge starts to move, the scraper arms go down and move with the bridge. After the scraper arms, controlled by switches, go down, the bridge moves. Features: Long service life. Easy maintenance. Heavy-duty design with strength. Fully automatic operation.

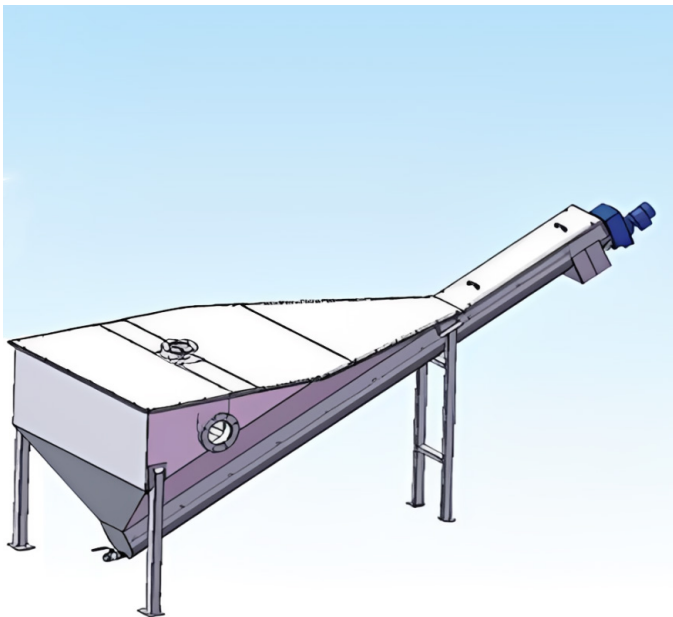

• Sludge Scrapers, Thickening & Dewatering

Efficient sludge handling is essential for reducing sludge volume and optimizing downstream treatment processes. The equipment includes several stainless steel components such as the filtrate outlet, wash water inlet, frame, and cover, while bolts and nuts are typically A2/A4 grade.

Key Advantages

- » High sludge thickening and dewatering efficiency.
- » Low energy consumption is contributing.
- » Continuous operation capability for reliable plant performance.
- » SCADA monitoring and automated control options.
- » Reduction of sludge volume helps lower transportation and disposal costs.

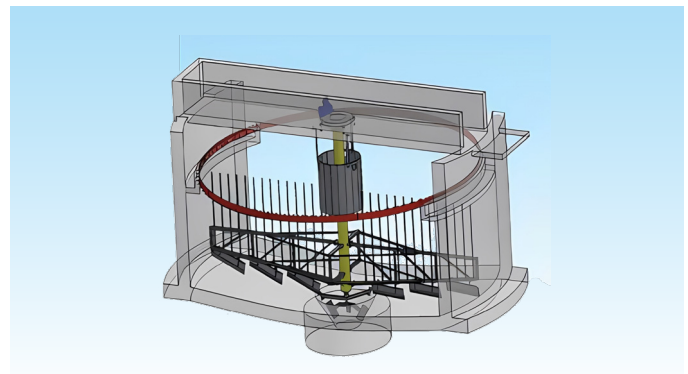

Conclusion

ARTAS wastewater treatment equipment offers a variety of mechanical systems to enhance the efficiency of treatment plants. This includes adjustable weirs, perforated screens, sludge scrapers, and processing systems that regulate water levels, remove solids, and manage sludge. Emphasizing durability and reliability, these technologies comply with international manufacturing standards. With over four decades of experience, ARTAS designs equipment for long operational life and easy maintenance. These systems are utilized in domestic and industrial wastewater treatment, irrigation projects, power plants, and process facilities.



Smart Sustainability
for Water & Energy



AquaEnergy Expo

Delivered in Egypt by **Smart Sustainability for Water & Energy Co.**

Supporting modern, energy-efficient WWTPs across Egypt through trusted global technologies.



High efficiency single stage & integrally geared turbo blowers for advanced aeration systems



High-performance diffusers

- Disc Diffusers ■ Tube Diffusers ■ Smart Strip Diffusers
- Coarse Bubble Diffusers



Control systems that automatically regulate the aeration process based on the actual oxygen demand in the biological treatment stage using AI algorithms.



Complete electromechanical solutions for wastewater treatment

- DAF ■ Grit & Grease Removal ■ Mixers ■ Penstocks & Weirs ■ Screens
- Scrapers ■ Thickeners & Dewatering Systems

Buyers Guide for Water and Renewable Energy Companies

Aqua Energy Virtual Expo

To add your company for free contact us
WhatsApp (+966 505308851)

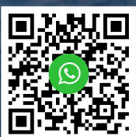

www.aquaenergyexpo.com



Filtralite® Filter Media: Driving Sustainable Water Treatment with Lower Energy and Reduced Carbon Footprint

Choosing the right filter media has a direct impact on energy consumption, operational costs, and environmental sustainability in water treatment. Filtralite® is a high-performance lightweight expanded clay filter media designed to enhance filtration efficiency while reducing energy use and carbon footprint. With Filtralite®, water treatment plants become smart, high-efficiency systems that deliver superior performance, improved water quality, and lower operational costs with reduced energy consumption.

How Filtralite® Helps Reduce Energy Consumption in Water Treatment Plants

Filtralite® is engineered with high porosity and lightweight structure compared to traditional media such as sand or anthracite.

These features allow for:

- Higher filtration rates
- Longer operating periods between backwashing cycles
- Fewer backwash cycles
- Reduced pumping energy demand

These advantages lead to lower operational costs and a significantly reduced carbon footprint.



Comparing the Carbon Footprint: Lightweight Aggregate vs Traditional Media

Traditional filter media like sand are denser and less porous, resulting in:

- Higher pressure loss inside filters
- More frequent backwashing
- Increased energy consumption during operation

In contrast, Filtralite® lightweight expanded clay aggregates provide high porosity and lower hydraulic resistance, improving water flow and reducing energy demand. Its lighter weight also reduces transport related emissions compared to heavier materials. The result is a lower lifecycle carbon footprint across filtration operation.

Innovation in Using Natural Materials by Filtralite®

Filtralite® is manufactured from naturally occurring clay that is thermally expanded to create a strong, porous, and lightweight structure.

Using natural raw materials combined with long service life reduces the need for frequent replacement and minimizes resource consumption.

The product aligns with Saint-Gobain's sustainability commitments, focusing on energy-efficient and environmentally responsible solutions for water and infrastructure sectors.

Case Study: Filtralite® Boosts Performance and Reduces Energy at Bedrichov Drinking Water Plant

The Bedrichov Drinking Water Treatment Plant in the Czech Republic faced high energy consumption due to frequent backwashing of



traditional sand filters, while needing to improve operational stability without expanding infrastructure.

The Challenge

- Rapid clogging of traditional sand media
- Frequent backwash cycles
- High energy consumption due to prolonged pump operation

The Results After Switching to Filtralite® Pure Mono-Multi

- Energy costs reduced by up to 75%
- Significant reduction in backwash cycles
- Longer operating periods and improved process stability
- Improved water quality

This case demonstrates how changing filter media alone can deliver substantial energy savings and significantly reduce a plant's operational carbon footprint.

Conclusion

By improving filtration efficiency, reducing energy consumption, and minimizing backwash cycles, Filtralite® offers a practical and scalable solution for sustainable water treatment operations. The outcome is not only higher technical performance but also lower carbon emissions and reduced lifecycle operational costs, making Filtralite® a smart choice for future-ready and sustainable water treatment plants.





Filtralite® Filter Media: Driving Sustainable Water Treatment with Lower Energy and Reduced Carbon Footprint



- **Lightweight, High-Efficiency Media**
Lower pressure loss and reduced pumping energy.
- **Up to 75% Energy Savings**
Fewer backwash cycles and longer filter runs.
- **Lower Carbon Footprint**
Reduced energy use and extended service life.
- **Case Study – Bedrichov Drinking Water Treatment Plant**
Up to 75% reduction in energy costs after switching to Filtralite® Pure Mono-Multi.

Aligned with Saint-Gobain sustainability goals, Filtralite® is a smart upgrade for sustainable water treatment plants.

How Al-Mousa Trading Co. Piping Technologies Are Redefining Performance in Mega Infrastructure Projects

High-performance piping systems are a critical backbone of mega infrastructure projects, directly impacting reliability, efficiency, and long-term operational performance. With the successful completion of the King Abdulaziz International Airport – South Terminal in Jeddah, Al Mousa Trading Co. reinforces its position as a trusted partner in delivering advanced piping solutions at scale, engineered to ensure durability, optimal flow performance, and uninterrupted operation in large, high-demand facilities serving millions of users annually.

Deep Expertise in Large-Scale Infrastructure Delivery

Al Mousa Trading Co. brings extensive experience in infrastructure and piping solutions, enabling it to successfully address the technical and operational challenges of mega projects such as international airports. Through an engineering-driven approach and strict quality standards, the company consistently delivers solutions that ensure safety, efficiency, and long-term reliability in mission-critical environments.

Strategic Partnerships that Add Real Value

In collaboration with AQUATERRA, Al Mousa Trading Co. supplied high-performance PPR and PPR Faser multilayer piping systems, selected to meet the demanding operational requirements of airport infrastructure. This partnership reflects the company's commitment to working with globally trusted manufacturers to deliver proven, high-quality technologies.

Aquaterra

Polypropylene Pipes and Fittings



Key Advantages of PPR and PPR Faser Piping Systems

The PPR and PPR Faser multilayer piping systems used in the South Terminal offer a range of performance advantages essential for large-scale infrastructure projects:

- High resistance to pressure and temperature fluctuations
- Excellent corrosion and chemical resistance
- Long service life with minimal maintenance requirements
- Lightweight structure for faster and more efficient installation
- High hygiene standards suitable for potable water applications
- Reduced lifecycle costs and improved operational efficiency

These advantages ensure reliable, long-term performance across critical water and utility networks within the airport.

Supporting National Infrastructure and Vision 2030

The successful completion of this project reflects Al Mousa Trading Co.'s ongoing commitment to supporting Saudi Arabia's national infrastructure development. By delivering durable and efficient piping solutions, the company contributes to projects aligned with Vision 2030, supporting sustainable growth, enhanced connectivity, and world-class aviation facilities.

Building Infrastructure Ready for the Future

The King Abdulaziz International Airport – South Terminal stands as a strong example of how engineering expertise, strategic partnerships, and advanced piping technologies come together to create resilient, future-ready infrastructure. Through a consistent focus on quality and performance, Al Mousa Trading Co. continues to deliver solutions that meet today's demands while supporting long-term operational success.





AquaEnergy Expo

Blue | Green | Sustainable | Smart

الموسى
AL MOUSA
شركة الموسى للتجارة
AL MOUSA TRADING CO.

How Al-Mousa Trading Co. Piping Technologies Are Redefining Performance in Mega Infrastructure Projects



- **High-Performance Piping:** PPR and PPR Faser systems ensure efficient, reliable operation under pressure, temperature, and chemical challenges.
- **Strategic Partnerships:** Collaboration with AQUATERRA delivers trusted, tested piping solutions.
- **Flagship Project:** King Abdulaziz International Airport – South Terminal in Jeddah showcases piping excellence at scale.
- **Supporting Vision 2030:** Contributing to sustainable, world-class infrastructure



AquaEnergy Expo

Florida, USA

250K+ Followers

60K+
Mailing List



12.5K+
YouTube
Subscribers



13.4K+
Telegram
Subscribers



67K+
Facebook
Subscribers



16K+
WhatsApp
Subscribers



40K+
LinkedIn
Subscribers



195+
Countries



900+
Jobs Offers



16
Employees



13.6M+
Products
View



1220 +
Companies



16400+
Virtual Expo
Products



13K+
References
Knowledge Hub



230+
Webinars



1.5K+
Articles
and News



15K+
Trainee





AquaEnergy Expo

M a g a z i n e

Blue | Green | Sustainable | Smart



Visit our Knowledge Hub



Read and Download More than 13000 Free and Open Access References in Water and Energy Science and Engineering

www.aquaenergyexpo.com

Are you looking for new customers?

Join Aqua Energy Virtual Expo and
increase your sales

Joining our Virtual Expo will help you
to increase your customers network, grow
your sales, publish your brand, find new
distributors, agents and open new markets

COUNTRIES 195+

COMPANIES 1220+

PRODUCTS 16400+



AquaEnergy Expo

Blue | Green | Sustainable | Smart

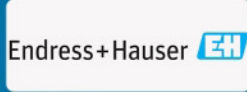





WEBINARS

Meet our Experts at Aqua Energy Expo Weekly Webinars



Eng. Tabish Ahmad

(Technical Support Engineer
at Al-Mousa Trading Co.)

"Integrated Pumping and Water
System Engineering: From Design
to Operation"



Friday, March 27th



8:00 to 10:00 PM
(Saudi Arabia Time)



Dr. Hossam Mostafa

"Fundamentals of Plant Hydraulics"



Saturday, March 28th



8:00 to 10:00 PM
(Saudi Arabia Time)





AquaEnergy Expo

Magazine

Blue | Green | Sustainable | Smart



WATER NEWS BRIEF

March | 2026

www.aquaenergyexpo.com

DuPont Water Solutions Expands Data-Driven WAVE PRO Design Tool with Reverse Osmosis and Nanofiltration

DuPont Water Solutions has expanded its free cloud-based WAVE PRO modeling software to include reverse osmosis (RO) and nanofiltration (NF) alongside its existing ultrafiltration and ion exchange capabilities; this unified platform allows water professionals to design comprehensive systems for drinking water, wastewater, and desalination applications using real performance data to simulate feedwater conditions, optimize energy usage, lower operational costs, and reduce environmental footprints!

Accessible securely across multiple devices, the upgraded tool seamlessly integrates DuPont’s industry-leading filtration products to provide highly accurate and efficient water treatment solutions worldwide.



Eighth Consent Requests and STID Proposal relating to Super Senior Issuer Funding



Thames Water Utilities Limited (TWUL) has secured £823 million in new commitments under its “Accordion” facility, raising its total available funding to £2.25 billion. To access these funds, the company has launched the Eighth Consent Requests and STID Proposal, seeking creditor approval to waive specific conditions and provide greater operational flexibility. The proposal includes requests to draw an initial £410 million, extend the June Release Condition to March 2026, and implement an exchange mechanism for creditors. With a voting deadline of 16 March 2026, these measures aim to stabilize liquidity while TWUL continues pursuing a long-term, market-led solution.

Veolia Strengthens Its Presence in India with two Unprecedented Mumbai Water Projects

Veolia has secured record-breaking contracts in India to provide technology and 15-year maintenance for Mumbai’s Bhandup and Panjrapur water treatment plants. Set to be operational by 2030, these facilities will supply over 60% of the city’s water using energy-efficient solutions. Leveraging 25 years of local experience, including a successful high-performance project in Nagpur, Veolia is expanding its footprint across several states. Beyond water, the company is advancing India’s “GreenUp” goals through hazardous waste management, Zero Liquid Discharge facilities, and pioneering carbon capture technology for industrial decarbonization, supporting the nation’s 2070 net-zero ambitions.



Xylem Inc. Announces \$1.5 Billion Share Repurchase Authorization

Xylem Inc. has announced that its Board of Directors authorized a new \$1.5 billion share repurchase program, effective immediately. CEO Matthew Pine stated that this move reflects strong confidence in the company’s strategy and its ability to generate sustainable cash flow. Xylem plans to execute these buybacks opportunistically through open market or private transactions while maintaining a disciplined approach to capital allocation. The company remains focused on balancing shareholder returns with investments in organic growth and innovation, ensuring a strong balance sheet and long-term value creation for its investors.



Kurita ranked 45th in Asia Pacific 50 Most Sustainable Corporations Ranking



Kurita Water Industries has been ranked 45th in the inaugural Asia Pacific 50 Most Sustainable Corporations Ranking (APAC50) by Corporate Knights. Selected from over 4,000 companies, Kurita was recognized for its high performance in sustainable revenue and investment. Central to this achievement is the group’s “CSV businesses,” which focus on water savings, GHG reduction, and resource recovery. Through its “PSV-27 Plan,” Kurita aims to solve global water issues and build a circular economy. By leveraging its deep water expertise, the company continues to deliver innovative technologies that provide environmental value while driving a sustainable global transition.

In Salem, Tamil Nadu, SUEZ will serve over 1 million people with quality drinking water, making it the Group’s largest water supply contract in India

Starting in 2027, SUEZ will manage a 25-year concession to modernize Salem’s water system, serving over 1 million residents. The project involves rehabilitating treatment plants, replacing 1,800 km of aging pipelines, and constructing 26 new reservoirs. By integrating digital tools such as SCADA and installing more than 234,000 metered connections, SUEZ aims to provide 24/7 water service while significantly reducing non-revenue water. This performance-based partnership builds on SUEZ’s extensive footprint in India, where it already serves 65 million people. The initiative reflects a shift toward resilient, high-tech urban infrastructure designed to tackle water scarcity through long-term operational efficiency.



Global Water Events

WaterReuse Symposium 2026

Date: From 8 to 11 March 2026

Location: Los Angeles, California

Annual WaterReuse Symposium is the premier conference on water recycling, attracting water professionals & water reuse practitioners globally for knowledge-sharing, networking, and collaboration.

The Symposium is the most comprehensive water recycling learning opportunity available, covering policy, technology, operations, and communications for applications that range from irrigation and potable reuse to onsite and industrial systems.

Website: watereuse.org



The Pump Industry Awards 2026

Date: 19th March 2026

Location: The Hilton at St. George's Park,
Burton upon Trent

The Pump Industry Awards is now recognised as one of the leading award ceremonies within the industrial arena.

Founded by the BPMA in 2000, the awards programme celebrates the achievements of pump companies and individuals who strive to go the extra mile.

Website: pumpindustryawards.com



Smart Water Systems

Date: 13 & 14 April 2026

Location: London, United Kingdom

The Annual Smart Water Systems conference is designed as a high-level forum to facilitate strategic dialogue and collaboration among water utility companies, solution providers, government authorities, & investment professionals.

The primary goal is to examine cutting-edge technologies, explore the latest industry trends, and share best practices to advance the UK and European smart water market.

Website: smgconferences.com



Global Water Summit

Date: From 18 to 20 May 2026

Location: Madrid, Spain

Climate extremes, rising energy demands, and pressures on capital mean the systems we rely on must adapt quickly. New technologies and AI will tackle such challenges, even as they place new demands on water. How do we strike a balance? This year's Global Water Summit is about turning that question into action.

Website: watermeetsmoney.com



WATERTECH CHINA

Date: From 9 to 11 June 2026

Location: Shanghai National Exhibition & Convention Center

WATERTECH CHINA 2026 is a premier water industry event, recognized as a significant “industry benchmark.” Building on the achievements of its previous edition, the event will take place from June 9 to June 11, 2026, at the renowned National Exhibition and Convention Center (NECC) in Shanghai.

Website: watertechsh.com



8th Annual International Conference and Exhibition Desalination Latin America

Date: 17 & 18 June 2026

Location: Santiago, Chile

The international investment conference and exhibition “Desalination Latin America” is the only business platform for developing effective strategies, sharing experiences, presenting new investment projects & innovations, and consolidating efforts of governments and businesses to implement desalination projects & to increase water supplies all over Latin America.

Website: desalinationlatinamerica.com



Indo Water 2026 Expo & Forum

Date: From 11 to 13 August 2026

Location: JIExpo Kemayoran, Jakarta, Indonesia

Join at Indo Water 2026 Expo & Forum, the Indonesia's No. 1 International Water and Wastewater Technology Event. Through exhibitions, conferences, seminars, and workshops, connect industry leaders, innovators, and professionals to showcase the latest technologies & solutions in water resource management, sewerage, industrial wastewater, purification, and irrigation.

Website: indowater.com



Aquatech Mexico

Date: From 1 to 3 September 2026

Location: Centro Banamex ,Av. del Conscripto
311, Mexico City

On 1st to 3rd September 2026, Aquatech Mexico will take place. You're invited to join other professionals, experts and investors interested in doing business in the water technology industries in the Americas. Join 3 action-packed days that provide the ideal platform to make profitable business relationships, exchange ideas and learn all about opportunities in this specific region for the water technology.

Website: aquatechtrade.com/mexico



WEFTEC 2026

Date: From 28 to 30 September 2026

Location: Ernest N. Morial Convention Center |
New Orleans, La. USA

Solving water challenges takes more than great ideas, it takes connection, collaboration, and action. At WEFTEC 2026, you'll find all three through cutting edge solutions, hands on learning experiences, and a global network of water professionals.

Website: weftec.org

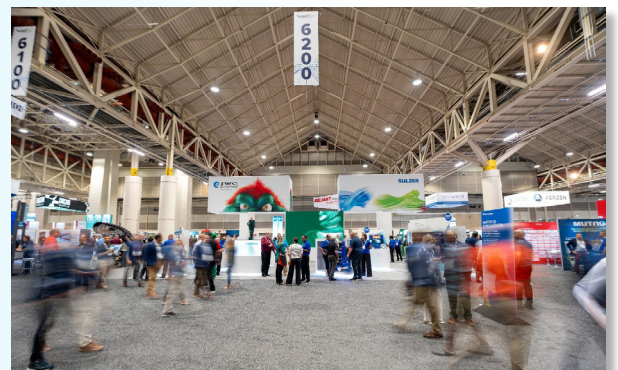

FiltXPO 2026

Date: 28 & 29 October 2026

Location: Minneapolis Convention Center,
Minneapolis, Minnesota

Grow your business by connecting with decision-makers across diverse industries who are actively sourcing advanced filtration and separation solutions.

Engage with 1,200+ filtration professionals from around the world. Expand your North American market reach.

Generate leads across high impact sectors, including: Water and Wastewater Treatment, Power Generation, Oil & Gas.

Website: filtxpo.com



Aquatech China

Date: From 28 to 30 October 2026

Location: 2345 Long Yang Road Pudong New Area
201204, China

China is making monumental investments in this sector, recognizing the critical need to address water shortages in its cities. With a mandate for cities to reclaim 25% of used water, the commitment is clear. This drive is further evidenced by the planned construction of 100 new sewage treatment plants.

Website: aquatechtrade.com/shanghai



Aquatech Asia

Date: From 25 to 27 November 2026

Location: Queen Sirikit National Convention
Center, Bangkok

The most recent addition to the well-known Aquatech portfolio is Aquatech Asia, which will be present at flagship trade shows in China, Mexico, and Amsterdam. Southeast Asian water experts, innovators, and decision-makers will come together at Aquatech Asia.

Website: aquatechtrade.com/asia

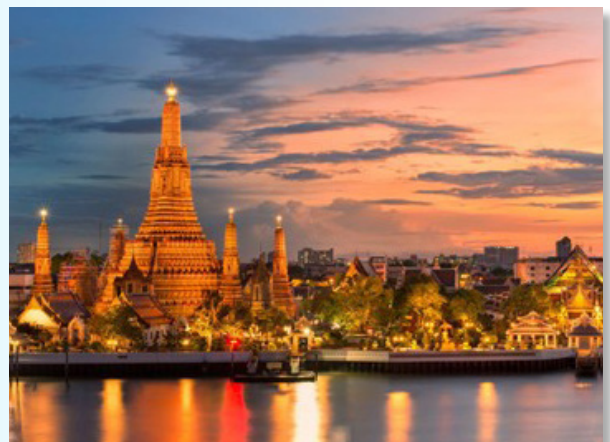



Naqaa Water Treatment Technology: Company Profile

Naqaa Water Treatment Technology is a specialized Egyptian company established in 2017, dedicated to providing integrated solutions in the fields of water desalination, water treatment, industrial maintenance, spare parts supply, and specialized treatment chemicals for water systems, cooling chillers, and steam boilers.

Since its establishment, Naqaa has focused on delivering reliable, high-efficiency, and sustainable engineering services that meet the growing demands of industrial, commercial, and agricultural sectors in Egypt and the region. The company operates with a clear vision centered on quality, innovation, environmental responsibility, and long-term customer partnerships.

Through continuous technical development, experienced engineering teams, and the use of modern treatment technologies, Naqaa has succeeded in building a strong reputation as a trusted provider of water treatment and industrial utility solutions.

Company Activities

Naqaa Water Treatment Technology provides a comprehensive range of professional services that cover the full lifecycle of water treatment and industrial utility systems. These activities include:

• Design, Supply, and Installation

The company designs and installs reverse osmosis desalination plants, filtration units, and complete water treatment systems tailored to each client's operational requirements and water quality conditions.

• Maintenance and Technical Support

Naqaa delivers periodic, preventive, and emergency maintenance services to ensure continuous system performance, minimize downtime, and extend equipment lifespan.

• Spare Parts Supply

The company supplies original and compatible spare parts for RO systems, filters, pumps,

chillers, and boilers, ensuring operational continuity and cost-effective maintenance.

• Treatment Chemicals

Naqaa provides a wide range of industrial treatment chemicals used to:

- Prevent scaling and salt deposition
- Reduce corrosion in pipelines and boilers
- Control biological growth
- Improve thermal and operational efficiency

These chemicals are carefully selected according to international quality and safety standards.

• Industrial Utilities Services

The company also supports steam boilers, cooling towers, and industrial chillers, offering chemical treatment programs, monitoring, and performance optimization.

Major Projects & References

Over the years, Naqaa Water Treatment Technology has successfully executed numerous projects across industrial, agricultural, and service sectors, demonstrating strong technical capability and project reliability.

- Water Treatment Plant Supply and Installation

Naqaa has supplied and installed treatment plants for several reputable entities, including:

- Al Gawhara Ceramic Industry
- Fab Steel Metal Works
- Swan Pack Carton Factory
- Pyramids Company
- The Egyptian Armed Forces
- Al Salam Metal Forming
- Safi Zad Mineral Water Company
- Memco Plast Factory
- Riyadh Farms
- Al-Tahawy Farm – El-Dabaa
- Al-Mahwar Agricultural Products
- Installation of multiple treatment units at Al-Adlia Association – Belbeis, Sharkia Governorate

These projects reflect Naqaa’s capability to deliver efficient, durable, and performance-driven water solutions in diverse environments.

- Supply of Chemicals and Spare Parts

Naqaa has also provided treatment chemi-

maintenance materials, and spare parts to several major industrial clients, including:

- Giza Spinning and Weaving Company
- Aqua Delta Mineral Water
- Petrotech Monorail Industry – New Administrative Capital
- Gas Misr Company

These collaborations demonstrate the company’s reliability as a long-term technical partner for industrial operations requiring consistent water treatment performance.

The projects listed above represent only part of Naqaa’s growing portfolio of successful achievements.

Company Products

Naqaa Water Treatment Technology offers a diverse portfolio of high-quality water treatment and industrial operation products, carefully selected to ensure durability, efficiency, and compliance with international standards.

Membranes and Filtration Media

- Reverse Osmosis (RO) Membranes
- Ion Exchange Resins
- Jacobi Activated Carbon
- Filtration Sand and Gravel



Chemical Treatment Materials

- Antiscalants
- Corrosion Inhibitors
- Salt Tablets for softening systems
- Citric Acid for cleaning and maintenance
- Specialized industrial treatment chemicals

Pumps, Filters, and Equipment

- Dosing Pumps
- Water Pumps and Pressure Pumps
- Bacterial Filter Candles in all sizes
- Jumbo Cartridge Filters
- Electric Motors (1 HP – 1.5 HP – 2 HP)

All supplied products undergo strict quality verification to guarantee optimal performance and long operational life under industrial conditions.

Quality, Safety, and Environmental Commitment

Naqaa Water Treatment Technology is committed to maintaining high standards of quality, occupational safety, and environmental protection throughout all operations.

The company adopts:

- Modern engineering design principles
- Safe chemical handling procedures
- Environmentally responsible treatment solutions
- Continuous monitoring and performance evaluation

This commitment ensures that Naqaa's solutions contribute to sustainable water management & reduced environmental impact.

Vision and Mission

• Vision

To become a leading regional provider of innovative and sustainable water treatment and industrial utility solutions.

• Mission

To deliver high-quality engineering services, reliable products, and professional technical support that enhance operational efficiency and create long-term value for clients.



Naqaa Water Treatment Systems represent a complete solution for obtaining pure and safe water with the highest standards of quality and efficiency. The stations rely on the latest filtration, purification, and desalination technologies, using high-quality materials that ensure long operational life and consistent performance across residential, industrial, and agricultural applications.

Naqaa stations are characterized by easy operation and maintenance, along with precise control systems that continuously monitor water pressure and quality. In addition, dedicated technical support and after-sales service guarantee the best customer experience.

With a strong commitment to delivering reliable and sustainable solutions, Naqaa remains the ideal choice for anyone seeking pure water and a healthier life.



A variety of water pumps used in pumping and water treatment systems are shown, appearing in different sizes and capacities to suit residential, industrial, and agricultural applications.

These pumps feature a strong metal structure and high-efficiency electric motors that help provide stable water pressure and reliable performance over long operating periods. Their organized arrangement on top of their original packaging also indicates their readiness for supply and installation within water stations or desalination and treatment systems.

This diversity of pumps reflects the ability of modern systems to meet multiple needs with



It works by exchanging harmful ions with safer ones, which helps improve water quality and protect pipes and equipment from scale buildup and deposits that could reduce efficiency over time.



Resin is one of the essential components in water treatment systems and is mainly used inside ion-exchange filters to remove water hardness and dissolved impurities such as calcium, magnesium, and unwanted salts.



The membrane is the core component of water purification and desalination systems, especially in reverse osmosis (RO) plants. It acts as an ultra-fine barrier that allows only pure water molecules to pass through while blocking dissolved salts, impurities, bacteria, and other harmful substances.

Membranes are distinguished by their high ability to remove a large percentage of salinity and contaminants, ensuring clean water suitable for residential, industrial, and medical uses.

Their performance depends on the quality of materials, proper operating pressure, and regular maintenance, which helps extend their service life and maintain the overall efficiency of the treatment system.

Therefore, the membrane is an indispensable element in any modern water treatment and desalination system due to the high purity and reliable operational efficiency it provides.



Antiscalant is a chemical used in water treatment and desalination systems, especially in reverse osmosis (RO) plants, to prevent the formation of scale and deposits on membrane surfaces and internal system piping.

It works by inhibiting the crystallization of salts and minerals such as calcium, magnesium, and silica, helping maintain efficient water flow and preventing membrane fouling or performance decline over time.

Using antiscalant regularly is an essential step in extending membrane lifespan, reducing maintenance and operating costs, and maintaining stable performance and high water quality within the treatment system.



Jacobi Activated Carbon is one of the most widely used types of activated carbon worldwide in water treatment and purification systems. It is distinguished by its high quality and strong efficiency in removing chlorine, organic substances, and unwanted odors from water.



The MYTHO – Type MX C/A chemical dosing pump is a device designed to inject precise amounts of chemicals into water systems to improve water quality and maintain efficient operation. It operates at 230 volts and 50/60 Hz, with a flow rate ranging from 5.5 to 7 liters per hour, making it suitable for use in water

treatment and desalination plants, boilers, cooling towers, and swimming pools. The pump is characterized by easy adjustment and accurate control of the dosing quantity, which helps in disinfecting water, preventing scale formation, and regulating pH levels with high precision, ensuring safe and stable operation of connected equipment and systems.



The LOREX – XVpm4-7 vertical multistage water pump is a practical and efficient solution for boosting water pressure and ensuring a stable flow across various residential and industrial applications. It features an operating power of 1.8 kW (approximately 2.4 HP), with a maximum flow rate of 130 liters per minute and a pumping head of up to 90 meters, making it ideal for water pressure boosting in buildings, irrigation systems, water treatment plants, and boiler or cooling tower feeding.

Its vertical multistage design supports high operating efficiency and balanced energy consumption, while allowing continuous operation and handling water temperatures of up to 40°C, delivering reliable performance and long service life.



An Automatic Control Valve Head is used in water filtration systems or water softener units to manage operating stages and self-cleaning cycles. It features fully automatic operation that reduces the need for manual intervention, optimizes water and salt consumption, and maintains consistent treatment quality.



The UV Electronic Ballast is a key unit used to operate and regulate UV lamps within water sterilization systems. It controls the electrical voltage and current to ensure stable and safe lamp operation, helping achieve high disinfection efficiency and extending the lamp's service life.

It also provides status indicators and alerts to monitor performance and signal when replacement is needed, making it an essential component for maintaining water quality and ensuring continuous, reliable operation in residential and industrial water treatment and sterilization systems.



The UV Water Sterilizer is an advanced and safe solution designed to ensure pure, bacteria-free, virus-free, and microorganism-free water without the need for any chemical additives. The device relies on high-efficiency ultraviolet technology housed a corrosion-resistant stainless steel chamber, providing fast and effective sterilization while preserving the water's natural taste and properties.

It features easy installation and operation, low energy consumption, and a long lamp service life, making it a reliable choice for homes, residential buildings, commercial facilities, and various water treatment systems to ensure consistently safe and healthy water quality.



Salt tablets are an essential material used in water softening systems to maintain the efficiency of the resin responsible for removing calcium and magnesium hardness from water. These tablets are manufactured with high purity and a compressed form that allows gradual dissolution inside the brine tank, ensuring a consistent and effective regeneration process without forming impurities or deposits that could affect system performance.

Salt tablets help extend the lifespan of treatment systems, reduce detergent consumption, and protect pipes and household appliances from scale buildup. They also contribute to producing softer water that is more suitable for daily use in homes and facilities, making them a necessary choice for maintaining water quality and ensuring continuous, efficient operation of softener systems.

المعادلة الصم من المكنو الصم

NAQAA

Website: www.naqaa-eg.com

Phone: +201001903176/ +20111853130

Address: Villa 155– 73rd District– 10th of Ramadan City– Egypt

Email: naqaa.amrnassar@gmail.com



Veolia: Leading the Way in Desalination Solutions for a Secure Future



With 50+ years of experience and 2,300+ plants built worldwide, Veolia leads sustainable desalination solutions to address global water scarcity through innovative technology and environmental stewardship. The world faces an unprecedented water crisis with multiple interconnected challenges. Global water demand is projected to increase by more than 50% by 2050, while half of the world's population already faces water scarcity. Climate change is intensifying these challenges through more frequent devastating weather events, with drought alone costing \$300 billion annually. The economic impact is severe water-scarce regions could lose 6% of GDP by 2050. This complex situation demands urgent, innovative, and affordable solutions to secure our water future.

Seawater Desalination

Veolia desalinate 13 million m³ of water every day in over 44 countries. The challenge? To tackle water stress in arid coastal regions and promote access to drinking water. Seawater desalination is an effective way of combating water stress in arid coastal regions.

It is a solution with great potential, considering that 40% of the world's population lives within 100 km of the sea and 25% within 25 km. Desalination is also a suitable means of providing drinking water in areas where natural water resources are subject to salinization: river estu-

aries and inland brackish or underground water.

Almost 300 Million People around the World Rely on Seawater Desalination, According to the International Desalination Association (IDA)

Desalination raises issues of public health, resilience and adaptation to the effects of climate change, regional dynamism, and even economic development. Today, it is essentially a municipal market. However, more and more industrial companies are turning to these technologies, even if the capacity of these plants is still lower than that of plants designed to produce drinking water.

How does Veolia Desalinate Seawater?

With a total processing capacity of approximately 13 million cubic meters of water per day, distributed across more than 2,300 sites in 44 countries worldwide, Veolia is the world leader in desalination. It supports municipalities and industrial sectors around the world in implementing desalination strategies, leveraging our extensive global expertise. After seawater extraction, it undergoes several pretreatment stages before desalination.



It offers two main technologies:

- **Distillation Desalination:** Salts are separated from the water through multiple evaporation cycles. This method is also known as thermal desalination;
- **Membrane desalination:** Filtration is achieved through reverse osmosis, where water is forced under high pressure through a membrane that traps up to 95% of salt particles and 99% of impurities.

It can combine these two processes to create hybrid desalination plants. The desalinated water then undergoes several additional treatment stages for demineralization and disinfection.

Fresh water: A Vital Challenge for coastal cities Facing Water Stress

What exactly is water stress? Simply put, it is a situation where the demand for water exceeds the resources available in a specific region, but this simple definition hides a complex reality that currently affects many areas.

For several years now, it has been seeing growing tension around water resources on the ground. The figures speak for themselves: 20% of European land and 30% of the continent's population are already affected by water stress every year, and the situation is only getting worse as a result of climate change. Droughts are becoming more frequent, groundwater levels are falling, and conflicts over water use are intensifying, particularly in coastal areas where demographic and tourist pressure is high.

This situation can be explained by several converging factors:

- Population growth in coastal areas
- Climate change, which intensifies droughts
- Over-exploitation of water resources
- Increasing urbanisation, which concentrates demand

For local elected officials and decision-makers, the question is no longer whether water shortages will occur but when and with what consequences for public health, the local economy, and social cohesion. Traditional solutions such as river abstraction, dam storage, and inter-basin transfers are showing their limitations,

both in terms of availability and environmental acceptability. Agriculture, industry, and domestic use are in direct competition with each other, requiring painful decisions. Even faced with this reality, it is tempting to consider seawater desalination only as a last resort, reserved for only the most extreme situations.

However, recent technological advances are changing the game: desalination can now be proactively integrate desalination into the water mix, complementing other levers (reducing losses, reusing wastewater, intelligent demand management).



Technological Developments in Desalination: From Constraint to Opportunity

Two technologies currently on the market:

1. Reverse osmosis: the energy efficiency revolution

Reverse osmosis now accounts for 70% of new seawater desalination plants worldwide. The concept is simple: under high pressure, salt water passes through a semi-permeable membrane that retains salts and impurities. The progress made over the last ten years has been spectacular: energy consumption has dropped from 4.5kWh/m³ to less than 3 kWh/m³, driven by membrane optimisation, energy recovery and process digitalisation.

Recent progress includes:

- More efficient and durable membranes
- Energy recovery systems using pressure exchangers
- Optimisation of pre-treatment processes to extend equipment life
- The use of digital technology and AI to implement predictive maintenance.

Focus on Barrel™: innovation for flexibility

Among the solutions it is developing to meet the needs of local authorities and industrial companies, Barrel™ deserves notable attention. This modular technology is revolutionising the approach to reverse osmosis desalination. This compact, scalable plug-and-play module can treat between 400 and 50,000 m³/day with a 25% smaller footprint and 0.05 kWh/m³ lower energy consumption compared to conventional systems.

The Barrel stands out for:

- Its modularity: easy adaptation to changing needs
- Its compactness: 25% smaller footprint compared to traditional solutions
- Its simplified maintenance: easy access to equipment and digital control
- Its energy efficiency: continuous performance optimisation

2. Desalination by distillation

Distillation, an ancient process of separating water and salt through evaporation, has benefited from major innovations. Although it consumes more energy, it remains relevant in cer-

tain industrial contexts, particularly for smaller facilities, for treating highly contaminated water, or in areas where thermal energy is available at low cost, such as operations with industrial waste heat recovery and cogeneration.

Concerns focused on:

- High energy consumption
- Brine management (highly saline wastewater)
- Impact on marine biodiversity

Today, through innovation, these challenges have been largely overcome:

Reducing our carbon footprint

Optimised brine management to protect marine biodiversity

Costs and profitability: the economic equation transformed

Investment and operating costs

Return on investment

Success Story: Advancing Sustainable Desalination with Veolia

Palma de Mallorca Seawater Desalination Plant:

On the island of Majorca, the Bahia de Palma desalination plant, which has been in operation since 1999, produces 64,800 m³ of drinking water every day using nine reverse osmosis lines. This strategic facility has made it possible to guarantee water supplies for the local population and millions of tourists while reducing pressure on groundwater reserves. The digitalization of operations has optimized energy consumption and reduced operating costs by 15% in five years.



Oman Seawater Desalination Plant:

In Sur, in the Sultanate of Oman, the integration of Barrel™ has enabled production of 5,000 m³/day with a 3% reduction in the overall cost of the plant and energy savings of 1.5%. The footprint has been reduced by 25%, facilitating integration into a constrained environment. Real-time data collection enables maintenance operations to be anticipated and membrane life to be optimized.

Another unique feature of the site is the installation of a 17-megawatt peak (MWp) solar power plant, with a total of 32,000 photovoltaic panels supplying power to the desalination plant.



How to Successfully Implement a Desalination Project?

- Analysis of the local context: assessment of water stress and current and future needs, as well as existing alternatives.
- Consultation with stakeholders: involvement of elected officials, users, associations, and economic actors to ensure social acceptability.
- Technical and environmental feasibility study: selection of the most suitable technology (reverse osmosis, distillation, modularity) and analysis of impacts on biodiversity.
- Cost and financing modeling: estimation of investments, operating costs, and potential savings (reduction of losses and valorization of by-products).
- Funding search and dossier preparation: mobilization of national, European, international, and private funding mechanisms; development of a robust business plan.

- Detailed design and choice of equipment: integration of innovations (Barrel™, digitalization, energy recovery), optimization of footprint.
- Obtaining regulatory approvals: compliance with local, European, and international standards; waste management; and environmental monitoring.
- Construction and commissioning: site management, team training, performance testing.
- Real-time supervision and optimization: deployment of digital platforms, predictive maintenance, and adjustment of operating parameters.
- Communication and information for users: transparency on water quality, promotion of environmental and economic benefits, as well as change management support.

Moving to Sustainable Water Security

Modern desalination fits perfectly into a sustainable development approach and offers:

- Security of supply independent of climatic hazards
- Consistent water quality that meets the most stringent standards
- Flexibility to adapt to changing needs
- Controlled environmental impact thanks to technological innovation

Conclusion

Desalination is currently undergoing a major evolution thanks to significant advancements. On one hand, the increasing integration of renewable energies, notably solar and wind, combined with energy optimization of processes, is profoundly transforming the sector. This energy transition not only allows for a considerable reduction in the carbon footprint of facilities, but also lowers operating costs, making desalination accessible to a greater number of regions around the globe. On the other hand, digitalization and artificial intelligence greatly improve the management of facilities. In particular, these technologies enable sophisticated predictive maintenance of reverse osmosis membranes, optimizing their lifespan and performance.



AquaEnergy Expo

M a g a z i n e

Blue | Green | Sustainable | Smart

Aqua Energy Expo Jobs platform

Aqua Energy Expo Jobs platform connects immense and diverse talents in the global Water and Energy industry .



www.aquaenergyexpo.com

Are you looking for new customers?

Join Aqua Energy Virtual Expo and
increase your sales

Joining our Virtual Expo will help you
to increase your customers network, grow
your sales, publish your brand, find new
distributors, agents and open new markets

COUNTRIES 195+

COMPANIES 1220+

PRODUCTS 16400+



Overcoming Infrastructure Barriers: Low-Cost Alternatives to Conventional Water Treatment

The global water crisis is one of the most significant health and development challenges facing humanity today. Approximately 2.2 billion people worldwide lack access to safe drinking water, exposing them to serious health risks. The problem is particularly acute in rural and impoverished areas, where communities suffer from inadequate infrastructure and limited resources. Sustainable and affordable water treatment solutions are needed to meet the needs of these populations. By focusing on simple and effective technologies, we can improve water quality and enhance public health, contributing to sustainable development.

The Global Water Crisis and the Urgent Need for Solutions

Access to safe drinking water is one of the most critical global public health and development challenges. The problem is especially severe in rural and low-income regions, where infrastructure limitations prevent access to centralized treatment systems.

In many communities, people rely on unsafe water sources such as rivers, lakes, and unprotected wells, increasing their exposure to harmful microorganisms and pollutants. This global crisis highlights the urgent need for innovative, affordable, and sustainable water treatment solutions that can be implemented in resource-limited settings.

Limitations of Conventional Water Treatment Technologies

Conventional water treatment systems are typically designed for urban areas with reliable electricity, advanced infrastructure, and skilled technical personnel. These systems involve multiple complex processes such as coagulation, sedimentation, filtration, and disinfection, which require mechanical equipment and continuous monitoring. While effective, these systems are often expensive to build, operate, and maintain.

In rural and underserved communities, these technologies are often impractical due to high installation costs, lack of technical expertise, and unreliable energy supply.

Additionally, dependence on imported components and specialized maintenance increases operational costs and limits sustainability. According to global water development reports, weak infrastructure and insufficient financing are major barriers to achieving universal access to safe drinking water. As a result, many conventional water treatment systems fail to operate effectively in low-resource environments, emphasizing the need for simpler and more resilient alternatives.

Low-Cost and Sustainable Water Treatment as an Alternative Solution

To address these challenges, researchers and engineers have focused on developing low-cost and sustainable water treatment systems. These systems are designed to operate efficiently using locally available materials and minimal external resources. Sustainable water treatment technologies prioritize simplicity, durability, and affordability, making them suitable for rural and underserved communities.

According to UNICEF and global water access reports, sustainable water solutions must consider local conditions, economic limitations, and community capacity to ensure long-term functionality. Sustainable systems reduce dependence on expensive infrastructure and enable communities to manage their own water resources effectively. Furthermore, environmentally friendly treatment technologies help reduce operational costs and environmental impact while improving access to safe drinking water.



Gravity-Based Water Treatment Systems: An Effective Innovation

Gravity-based water treatment systems represent one of the most effective low-cost innovations for rural water treatment. These systems use natural gravitational force to move water through different treatment stages without requiring pumps or electricity. This significantly reduces energy consumption and operational costs. Water purification typically involves processes such as sedimentation, filtration, and disinfection, which remove suspended particles and microorganisms. Research shows that water treatment processes can effectively remove harmful particles and bacteria, improving water quality and safety. Gravity-based systems are particularly beneficial in remote areas where electricity is unreliable or unavailable. By eliminating mechanical components, these systems reduce maintenance requirements and improve long-term reliability.

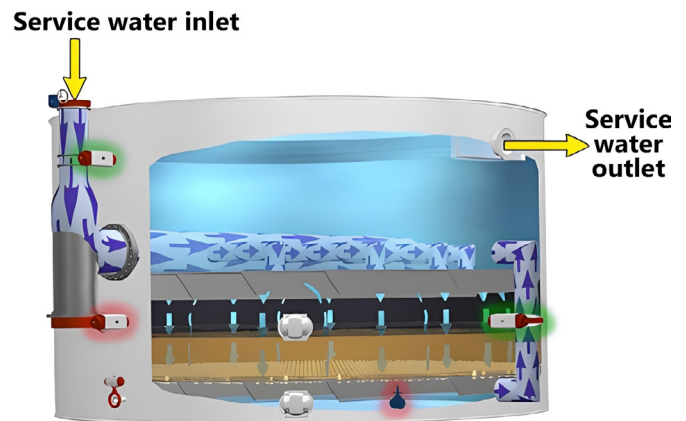

Effectiveness of Water Treatment Systems in Improving Water Quality

Water treatment systems significantly improve water quality by removing contaminants, suspended particles, and harmful microorganisms. One of the key indicators of water quality is turbidity, which measures the concentration of suspended particles in water. High turbidity levels are associated with increased microbial contamination and health risks.

Research studies show that water treatment processes can effectively reduce turbidity and remove contaminants, making water safer for

human consumption. By improving water clarity and removing harmful microorganisms, treatment systems reduce the risk of waterborne diseases and improve overall public health. Water purification systems also help remove bacteria such as *E. coli*, which is commonly found in contaminated water and can cause severe illness.

Sustainability and Long-Term Operational Benefits

Sustainable water treatment systems are designed to operate efficiently over long periods with minimal maintenance. These systems use simple designs, locally available materials, and energy-efficient processes, reducing operational costs and improving reliability.

According to United Nations water sustainability reports, achieving universal water access requires innovative technologies that are cost-effective, resilient, and adaptable to local conditions. Sustainable systems help ensure continuous access to safe water while reducing dependence on external technical support.

Additionally, sustainable treatment systems contribute to environmental protection by reducing energy consumption and minimizing chemical use.



Social, Economic, and Health Benefits of Safe Drinking Water

Access to safe drinking water has significant social, economic, and health benefits. Clean water reduces the spread of infectious diseases, improves hygiene, and enhances overall public health. According to the WHO, access to safe water is essential for preventing diseases. Safe water access also improves education and economic productivity.

In many developing regions, women and children spend hours collecting water from distant sources. Providing local access to clean water reduces this burden and allows individuals to focus on education and economic activities.

Furthermore, access to safe water contributes to poverty reduction and sustainable development by improving quality of life and supporting community growth.

The Future of Water Treatment: Innovation and Sustainability

The future of global water treatment depends on the development and implementation of innovative, sustainable, and affordable technologies. According to United Nations sustainability reports, achieving universal access to safe drinking water requires investment in new technologies, infrastructure, and community-based solutions.

Low-cost and energy-efficient systems are particularly important for addressing water challenges in underserved communities. These technologies provide reliable, sustainable solutions that can operate independently of complex infrastructure. By focusing on innovation, sustainability, and accessibility, global efforts can significantly improve water security and public health worldwide.

Conclusion

The global water crisis affects billions, and conventional treatment systems are often too costly and complex for underserved communities. Sustainable, gravity-based water treatment technologies provide affordable, reliable alternatives suitable for resource-limited settings. These systems improve water quality, reduce disease, and support overall community well-being, while also contributing to economic growth, education, and social progress. Achieving universal access to safe drinking water will require continued innovation, investment, and global cooperation, with sustainable technologies playing a key role in securing a healthier future worldwide.



MBBR Technology: The Sustainable Solution for Modern Industrial Wastewater Treatment

Industrial wastewater treatment is a critical issue in our modern era, given increasing environmental concerns and pressure on water resources. With growing environmental regulations, industries are adopting advanced technologies to ensure compliance & minimize environmental impact.

The Moving Biofilm Reactor (MBBR) is one such innovation, offering an efficient and flexible wastewater treatment solution and addressing current trends in wastewater treatment, including the shift towards decentralized systems, MBBR technology, and the importance of sustainability in this field to ensure environmental protection and the sustainable management of water resources.

Stricter Environmental Regulations

Environmental regulations governing industrial wastewater treatment have become significantly stricter in recent years due to growing environmental concerns and water scarcity.

Governments and regulatory bodies have introduced updated directives requiring industries to remove higher levels of pollutants such as nitrogen, phosphorus, organic matter, and emerging contaminants like PFAS & microplastics. These regulations aim to protect ecosystems, improve public health, and ensure sustainable water management. Industries that fail to comply with these regulations may face penalties, fines, or operational restrictions. As a result, companies are increasingly investing in advanced wastewater treatment technologies to ensure compliance and reduce environmental impact.

Shift to On-Site and Decentralized Treatment

Traditionally, many industries relied on centralized municipal wastewater treatment systems. However, due to stricter regulations and increased wastewater volumes, industries are now adopting on-site and decentralized treatment systems.

These systems allow industries to treat wastewater directly at the source before discharge or reuse. On-site treatment provides several benefits, including improved control over wastewater quality, reduced discharge fees, and enhanced regulatory compliance. It also reduces the burden on municipal treatment plants and supports water reuse initiatives.

Biofilm Technologies (MBBR)

Moving Bed Biofilm Reactor (MBBR) technology is an advanced biological treatment method that uses microorganisms attached to carriers to break down pollutants. This technology offers higher efficiency compared to traditional activated sludge systems.

MBBR systems require less space, produce less sludge, and provide more stable treatment performance. They are particularly suitable for industrial wastewater with variable loads and high organic content.

A Scientific Explanation of MBBR Technology

Mobilized Biological Wind (MBBR) technology is one of the newest and most important methods used in wastewater treatment. This technology relies on the use of microorganisms attached to carriers that react with pollutants, making it more efficient than traditional systems such as activated sludge systems.

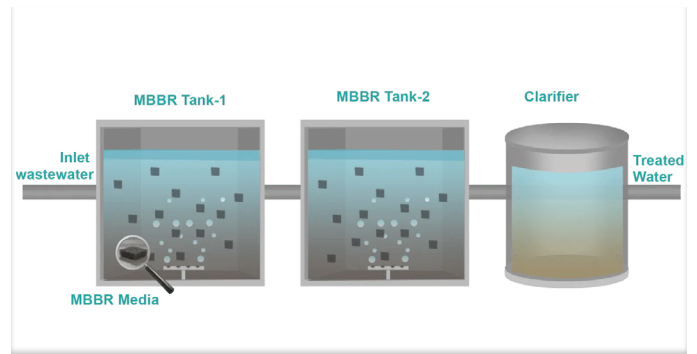

How MBBR Technology Works

MBBR technology is based on the principle of using biological carriers (such as plastic balls or other materials) that allow microorganisms to grow on them. These microorganisms break down the pollutants present in the wastewater. Here are the steps of the process:

- **Water Intake:** Wastewater is received at the treatment unit where it is sorted and its components are analyzed.
- **Water Flow:** The water flows through the MBBR carriers, where the microorganisms are located.
- **Biological Reaction:** The microorganisms react with the pollutants, leading to their decomposition.
- **Solid Separation:** After the decomposition process, the remaining solids are separated from the treated water.
- **Discharge:** Treated water is discharged after ensuring it meets environmental standards.



Comparison Between Conventional Systems and MBBR Technology

Efficiency

- **MBBR:** Offers high treatment efficiency thanks to the increased surface area available for microorganism growth. It is also better able to handle varying loads of pollutants.
- **Conventional Systems:** Such as activated sludge systems, may experience efficiency issues when loads change, leading to instability in the quality of treated water.

Space Required

- **MBBR:** Requires less space compared to conventional systems, as it can be installed in confined spaces. This makes it ideal for use in urban areas or industries with limited space.
- **Conventional Systems:** Require larger spaces due to the need for large sludge storage tanks.

Sludge Production

- **MBBR:** Produces smaller quantities of sludge, reducing disposal costs. This is a significant environmental benefit.
- **Conventional Systems:** Often produce large quantities of sludge, increasing the costs associated with its disposal.

Control and Management

- **MBBR:** Intelligent control systems enable continuous performance monitoring, helping to improve efficiency and reduce energy consumption.
- **Conventional Systems:** May require more complex control processes and regular maintenance to maintain performance.

Cost

- **MBBR:** While initial installation costs may be higher, lower operating costs and space savings make it more economical in the long run.
- **Conventional Systems:** Installation costs may be lower, but higher operating costs can lead to higher overall costs.

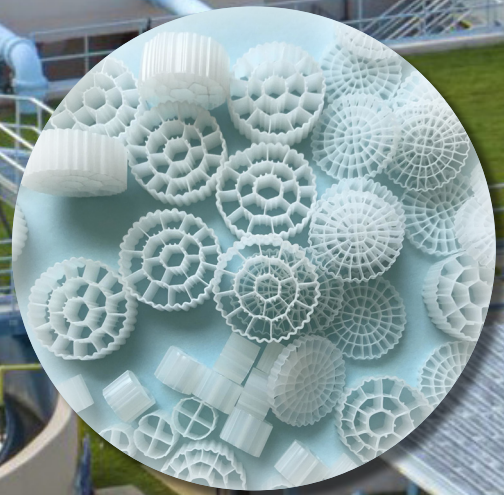

Benefits of MBBR Technology

- **Versatile Treatment Capability:** MBBR technology can be used to treat various types of wastewater, including industrial and agricultural wastewater.
- **Flexibility:** MBBR systems can be easily modified to meet changing treatment needs.
- **Sustainability:** Contributes to reducing environmental impact by lowering pollutant emissions.

Benefits of Modular Systems

Modular wastewater treatment systems consist of prefabricated units that can be easily installed, expanded, or relocated. These systems provide flexibility and scalability, allowing industries to adjust treatment capacity based on production needs.

Modular systems also reduce installation time, construction costs, and operational disruptions. They are ideal for industries with limited space or changing wastewater volumes.

Digital Monitoring and Smart Control

Digital monitoring technologies enable real-time monitoring of wastewater treatment processes using sensors and control systems. These systems help detect issues early, optimize performance, and reduce energy and chemical consumption.

Smart monitoring improves operational efficiency, ensures compliance with regulations, and reduces maintenance costs.



Compliance and Environmental Standards

Compliance with environmental standards is essential for protecting ecosystems and avoiding legal penalties. Wastewater treatment systems must meet strict discharge limits and performance requirements.

Advanced treatment technologies help industries meet these standards and improve environmental sustainability.

Water Reuse and Sustainability

Water reuse is becoming increasingly important due to water scarcity and sustainability goals. Treated wastewater can be reused for industrial processes, irrigation, or cooling.

Water reuse reduces freshwater consumption, lowers costs, and supports sustainable resource management.

Future Readiness and Sustainability

Future-ready wastewater treatment systems must be flexible, scalable, and capable of handling new regulations and emerging contaminants. Industries must invest in advanced and sustainable technologies to remain compliant and competitive.

Sustainable wastewater management supports environmental protection, resource conservation, and long-term operational success.

Conclusion

MBBR technology represents a significant advancement in wastewater treatment. Thanks to its high efficiency, flexibility, and low operating costs, it is an ideal choice for many industries seeking to comply with stringent environmental standards. Compared to traditional systems, MBBR offers numerous advantages that make it the preferred option in many applications. It is essential for industries to invest in this advanced technology to achieve their sustainability goals and protect the environment, thus contributing to a more sustainable future.

Watch more than 230

Online free webinars in the field of
"Water and Energy Engineering and Science"
on our YouTube channel





**Phosphate Management Revolution:
Innovative Solutions for Protecting
Water Resources and Achieving
Environmental Sustainability**

Phosphates are essential for growth and development in living organisms, playing a pivotal role in agriculture and industry. However, the excessive use of phosphates particularly in fertilizers can lead to water pollution through nutrient enrichment, causing serious environmental problems such as toxic algal blooms. Addressing these challenges requires the adoption of effective, sustainable, and forward-thinking technologies for phosphate removal from wastewater.

The Impact of Phosphates on Water Pollution

Phosphates are chemical compounds containing phosphorus, a key nutrient required by plants and animals. While phosphorus is vital for life, excessive concentrations in water bodies can cause a form of pollution known as eutrophication. Eutrophication occurs when water becomes overly enriched with nutrients. Although this process can develop naturally over time, human activities significantly accelerate it. Elevated nutrient levels stimulate excessive algal growth, known as algal blooms, which block sunlight from reaching underwater vegetation. As these plants die and decompose, oxygen levels in the water decrease, threatening fish, aquatic organisms, and the overall ecosystem balance.

Sources of Phosphorus in Water Pollution

• Agricultural Runoff

Phosphorus is a major component of agricultural fertilizers. Rainfall can wash unused phosphates from farmland into nearby rivers and lakes. This type of pollution is classified as non-point source pollution, as it originates from widespread land activities rather than a single discharge outlet.

• Human and Animal Waste

Urban wastewater, septic systems, and sewage discharges are major contributors to phosphorus pollution. Human sewage is one of the most significant urban sources of nutrient contamination. Additionally, increased livestock production generates large quantities of manure, which can elevate phosphorus levels in surrounding water bodies if not properly managed.



Traditional Methods for Phosphate Removal

• Chemical Precipitation

Chemical precipitation is one of the most common and effective methods for phosphorus removal. It involves adding mineral salts such as aluminum, calcium, or iron compounds to wastewater. These substances react with phosphate ions to form insoluble compounds that can be removed through sedimentation or filtration.

For example, lime treatment raises wastewater pH, promoting the formation of calcium phosphate precipitates. While highly efficient, this method can produce significant volumes of sludge that require proper handling and disposal, increasing operational costs.

• Filtration Techniques

Filtration systems including sand filters, disc filters, drum filters, and membrane filtration remove particulate phosphorus by capturing suspended solids. These systems can operate independently or alongside biological and chemical treatments.

Membrane filtration, particularly in tertiary treatment stages, offers high phosphorus removal efficiency and precise control. Many filtration systems can also be integrated into existing treatment plants without major infrastructure modifications.

Advanced and Sustainable Technologies

• Enhanced Biological Phosphorus Removal (EBPR)

EBPR utilizes specialized microorganisms capable of absorbing and storing phosphorus within their cells under controlled anaerobic and aerobic conditions. This environmentally friendly approach reduces reliance on chemical additives while achieving effective phosphorus removal.

• Advanced Oxidation and Electrochemical Processes

Modern wastewater treatment increasingly incorporates advanced oxidation and electrochemical technologies. These systems generate powerful oxidizing agents directly within treatment facilities to remove phosphorus and other

contaminants.

Such technologies can:

- Oxidize organic and inorganic pollutants
- Assist in phosphorus coagulation and precipitation
- Provide disinfection benefits

By generating treatment agents on-site, these systems reduce dependence on bulk chemical transportation and storage, enhance dosing precision, improve safety, and ensure consistent treatment performance. Many are compact, automated, and energy efficient, allowing remote monitoring and minimal manual intervention.





The Future of Phosphate Management

As environmental regulations continue to tighten globally, wastewater treatment facilities must adopt more reliable and sustainable phosphorus control strategies. Advanced treatment solutions support:

- Ecosystem protection
- Safeguarding drinking water sources
- Reduced carbon footprint associated with chemical logistics
- Greater operational resilience and efficiency

Effective phosphate management is not only a regulatory necessity but also a critical step toward sustainable water resource management.

Conclusion

Phosphate management presents a significant environmental challenge that requires coordinated action from governments, industries, agricultural sectors, and communities. While traditional methods remain important, modern and sustainable technologies provide enhanced efficiency, safety, and environmental performance.

Investing in innovative phosphate removal strategies helps improve water quality, reduce pollution, and protect natural ecosystems—ensuring cleaner water and a more sustainable future for generations to come.

Buyers Guide for Water and Renewable Energy Companies

Aqua Energy Virtual Expo

December 2024



To add your company for free contact us WhatsApp (+966 50 530 8851)

www.aquaenergyexpo.com





AquaEnergy Expo

Magazine

Blue | Green | Sustainable | Smart



ENERGY NEWS BRIEF

March | 2026

www.aquaenergyexpo.com

ACCIONA Energía installs solar system to decarbonize GrafTech's Navarra facility

ACCIONA Energía has completed a 1.56 MWp on-site solar installation at GrafTech's production facility in Navarra, Spain. Operating under a 15-year "energy-as-a-service" PPA, the system features over 2,300 high-efficiency bifacial modules covering 11,500 square meters of roofs and parking canopies. Designed for total self-consumption, the project will generate roughly 2GWh of renewable electricity annually without grid exports. This partnership allows GrafTech to decarbonize and optimize energy costs with zero upfront investment, while ACCIONA handles all installation and maintenance. The project also included infrastructure upgrades, such as replacing fiber cement roofing, further supporting GrafTech's long-term sustainability and industrial efficiency goals.



Electricity: TotalEnergies partners with AllianzGI to develop 800 MW of battery storage projects in Germany



TotalEnergies and Allianz Global Investors have partnered to develop an 800 MW battery storage portfolio in Germany, representing a €500 million investment in critical energy infrastructure. AllianzGI acquired a 50% stake in 11 projects developed by Kyon Energy, which are slated to be operational by 2028. Utilizing Saft's next-generation battery technology, these assets will reduce grid congestion and provide the flexibility necessary to support Germany's rapid renewable energy growth. This "clean firm power" strategy allows TotalEnergies to optimize capital while strengthening its presence across the entire German power value chain, from generation to 24/7 low-carbon supply.

Iberdrola, in the world's top 100 AI projects to promote sustainability

UNESCO-linked body IRCAI has recognized Iberdrola's MeteoFlow platform as one of the world's top 100 AI projects for sustainable development. Developed internally since 2004, the platform uses artificial intelligence and neural networks to predict electricity production across wind and solar facilities with high accuracy. By forecasting output from one hour to ten days in advance, MeteoFlow optimizes grid management and facilitates the integration of renewables into the energy system. This "Excellent" rated innovation reduces emissions and protects infrastructure, showcasing Iberdrola's two-decade commitment to using Big Data for a cleaner, more efficient, and electrified global economy.



LONGi Honored in S&P Global Sustainability Yearbook 2026

LONGi has been named an “Industry Mover” in the S&P Global Sustainability Yearbook 2026, ranking in the top 4% of the semiconductor industry. This recognition follows the company’s significant year-over-year ESG score improvement in the 2025 Corporate Sustainability Assessment. Guided by its “LIGHT” philosophy, LONGi excels in climate strategy, waste management, and biodiversity. Notably, the company has committed to net-zero emissions by 2050 and became a 2025 TNFD Adopter to target “Net Zero Loss” of biodiversity. By integrating digital ESG management into its global supply chain, LONGi continues to lead in transparent disclosure and sustainable R&D innovation.



First Solar, Oxford PV Enter into Patent Licensing Agreement for US Markets



First Solar has entered a non-exclusive patent licensing agreement with Oxford PV, gaining access to a leading global portfolio of perovskite solar technologies. This strategic move allows First Solar to accelerate the development and potential U.S. manufacturing of thin-film perovskite devices for utility, commercial, and residential markets. Having invested over \$2 billion in R&D, First Solar is leveraging its Ohio-based development line to meet efficiency and stability milestones. This partnership underscores growing industry confidence in perovskites as the next generation of solar technology while reinforcing both companies’ commitment to safeguarding intellectual property rights.

Shell to sell Jiffy Lube International and Premium Velocity Auto to Monomoy Capital Partners

Shell USA subsidiary Pennzoil Quaker State Company has agreed to sell Jiffy Lube International and its subsidiary, Premium Velocity Auto, to Monomoy Capital Partners for \$1.3 billion. While the sale includes the iconic Jiffy Lube brand and its franchised network, Shell will maintain its core lubricants business, including the Pennzoil, Quaker State, and Rotella brands. As part of the deal, Shell secured a long-term supply agreement to continue providing lubricants to the service centers. This transaction, expected to close in late 2026, allows Shell to monetize non-core assets and reinvest in higher-return opportunities within its global portfolio.



Global Energy Events

Energy Storage USA 2026

Date: 24 & 25 March 2026

Location: Renaissance Dallas Addison Hotel

As the U.S. energy storage market scales rapidly in the wake of policy shifts and technological breakthroughs, the Energy Storage Summit USA 2026 returns to connect the entire value chain from storage developers and utilities to investors, grid operators, and innovators.

Website: storageusa.solarenergyevents.com



SolarLUS USA

Date: 24 & 25 March 2026

Location: Renaissance Dallas Addison Hotel

For five editions, Large Scale Solar USA has convened the people driving utility scale solar development across the US. From 2026, the Summit becomes SolarPLUS USA, a rebrand that mirrors where the market is heading. Developers, investors and utilities are now managing hybrid assets, multi-state pipelines, storage co-location and complex grid challenges.

Website: lssusa.solarenergyevents.com



Renewables Procurement & Revenue Summit

Date: 20 & 21 May 2026

Location: Hilton London Tower Bridge

The Renewable Procurement & Revenue Summit 2026 brings together the UK and Ireland's renewable energy ecosystem to address these realities head on. Over two days, featuring dedicated Buyer and Seller streams, the Summit blends plenary discussions, expert panels, case studies, executive interviews, and peer to peer roundtables to deliver actionable insights on market trends, risk mitigation, and innovative contracting solutions.

Website: renewablerevenue.co.uk



The Battery Show Europe

Date: From 9 to 11 June 2026

Location: Messe Stuttgart, Germany

Join Peers at the Leading Meeting Place for the Advanced Battery and H/EV Technology Community. Meet battery manufacturers, suppliers, engineers, thought leaders, and decision makers for a conference and battery tech expo focused on the latest developments in the advanced battery and automotive industries.

Website: thebatteryshow.eu



PV ModuleTech USA

Date: 16 & 17 June 2026

Location: Napa, USA

The event will gather the key stakeholders from solar developers, solar asset owners and investors, PV manufacturing, policy making and all interested downstream channels and third-party entities

Website: pvtechconferences.com/pv-moduletech-usa



Intersolar Europe

Date: From 23 to 25 June 2026

Location: At Messe München

As the world's leading exhibition for the solar industry, Intersolar Europe demonstrates the enormous vitality of the solar market. For more than 30 years, it has been providing a networking opportunity for the key players from manufacturers, suppliers and distributors to installers, service providers, project developers, planners and start-ups all under the motto "Connecting Solar Business".

Website: intersolar.de



International Energy Storage & Battery Conference & Exhibition

Date: From 9 to 11 October 2026

Location: Shanghai World Expo Exhibition and Convention Center

Council (Preparatory), New Energy Industry Association for Asia and the Pacific, European Association of Energy Storage Trade, China Electric Power Construction Association, Shanghai Federation of Industrial Economics, Shanghai New Energy Industry Association, and the SNEC PV, Storage & Hydrogen Energy Alliance, the SNEC ES+ 13th (2026) International Energy Storage & Battery Conference & Exhibition (abbreviated as “2026 SNEC ES+ Exhibition”) will be grandly held.

Website: energystorageexpo.org



Battery Asset Management Summit Europe 2026

Date: 2 & 3 December 2026

Location: Hotel nhow Roma, Italy

Europe saw unprecedented growth in energy storage last year, with a record-breaking 12GW installed, and Battery Energy Storage Systems (BESS) continued to dominate this expansion. What continued to set this summit apart was the strength of its community. Through technical workshops and structured networking, stakeholders came together not only to learn but also to work through the real operational challenges shaping Europe’s storage landscape.

Website: batteryeurope.solarenergyevents.com





AquaEnergy Expo

Magazine

Blue | Green | Sustainable | Smart

Now for Free & for a Limited Time

Show your products in the global virtual expo for water and energy products

Joining the virtual expo will help you to increase your customers network, grow your sales, publish your brand, find new distributors and agents and open new markets

*The virtual expo of water and energy products contains more than **16400** products and more than **1220** companies from more than **195** countries around the world*



To add your company for free contact us

WhatsApp (+966 505308851)

www.aquaenergyexpo.com